

MOUNTING AND OPERATING INSTRUCTIONS

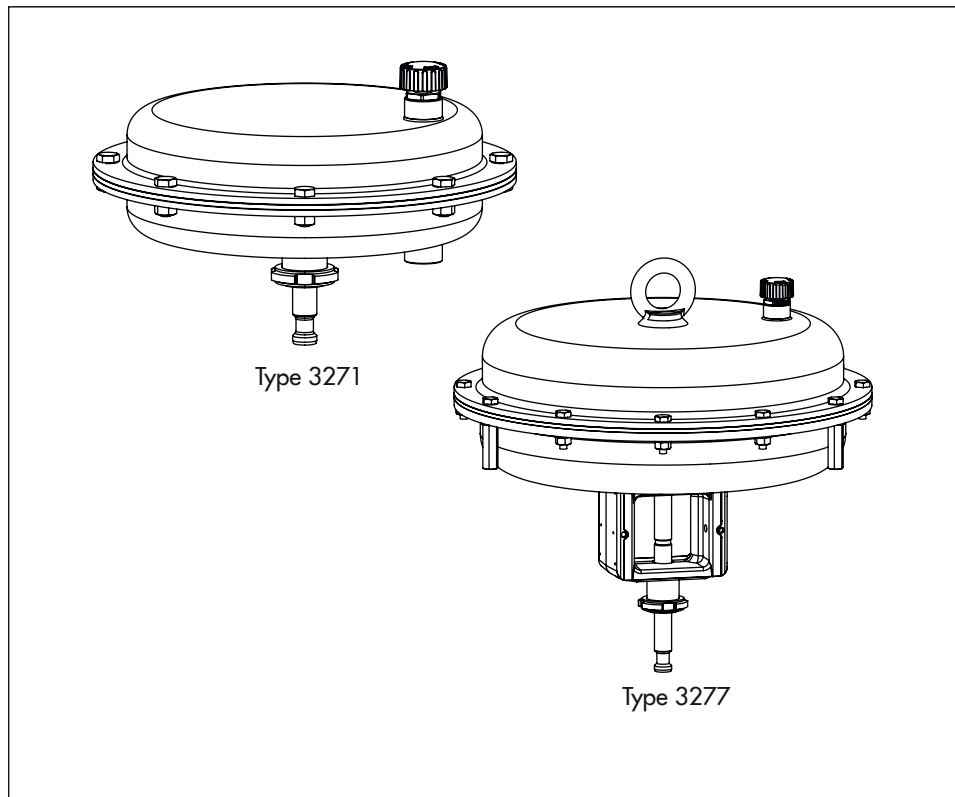

EB 8310-6 EN

Translation of original instructions



Types 3271 and 3277 Pneumatic Actuators

Actuator area: 240, 350 and 700 cm²

Note on these mounting and operating instructions

These mounting and operating instructions assist you in mounting and operating the device safely. The instructions are binding for handling SAMSON devices. The images shown in these instructions are for illustration purposes only. The actual product may vary.

- For the safe and proper use of these instructions, read them carefully and keep them for later reference.
- If you have any questions about these instructions, contact SAMSON's After-sales Service (aftersaleservice@samsongroup.com).



Documents relating to the device, such as the mounting and operating instructions, are available on our website at www.samsongroup.com > **Service & Support > Downloads > Documentation.**

Definition of signal words

DANGER

Hazardous situations which, if not avoided, will result in death or serious injury

WARNING

Hazardous situations which, if not avoided, could result in death or serious injury

NOTICE

Property damage message or malfunction

Note

Additional information

Tip

Recommended action

1	Safety instructions and measures	1-1
1.1	Notes on possible severe personal injury	1-3
1.2	Notes on possible personal injury	1-4
1.3	Notes on possible property damage	1-5
1.4	Warnings on the device.....	1-6
2	Markings on the device	2-1
2.1	Actuator nameplate.....	2-1
3	Design and principle of operation	3-1
3.1	Type 3271	3-1
3.2	Type 3277	3-2
3.3	Direction of action.....	3-2
3.4	Signal pressure routing.....	3-3
3.4.1	Type 3271	3-3
3.4.2	Type 3277	3-3
3.5	Fail-safe action	3-3
3.5.1	Actuator stem extends	3-3
3.5.2	Actuator stem retracts.....	3-3
3.6	Versions	3-4
3.7	Accessories	3-4
3.8	Technical data	3-5
4	Shipment and on-site transport	4-1
4.1	Accepting the delivered goods	4-1
4.2	Removing the packaging from the actuator	4-1
4.3	Transporting and lifting the actuator	4-1
4.3.1	Transporting the actuator	4-2
4.3.2	Lifting the actuator	4-2
4.4	Storing the actuator.....	4-5
5	Installation	5-1
5.1	Preparation for installation.....	5-1
5.2	Mounting the device.....	5-1
5.2.1	Mounting the actuator onto the valve.....	5-2
5.2.2	Connecting the air supply	5-6
6	Start-up	6-1
6.1	Spring compression.....	6-2
6.1.1	Tensioning the springs	6-2
6.1.2	Increasing the actuator thrust	6-3
6.1.3	Adapting the travel range.....	6-4

Contents

6.2	Travel stop	6-4
6.2.1	Bottom travel stop (minimum travel)	6-4
6.2.2	Top travel stop (maximum travel)	6-4
6.3	Version with handwheel	6-5
6.3.1	Extending the actuator stem manually	6-6
6.3.2	Retracting the actuator stem manually	6-6
7	Operation	7-1
7.1	Throttling service	7-1
7.2	On/off service	7-1
7.3	Manual mode (versions with handwheel only)	7-2
7.4	Additional notes concerning operation	7-2
8	Malfunctions	8-1
8.1	Troubleshooting	8-1
8.2	Emergency action	8-2
9	Servicing and conversion	9-1
9.1	Periodic testing	9-2
9.2	Preparation for servicing or conversion work	9-3
9.3	Mounting the actuator on the valve after servicing or conversion work	9-3
9.4	Service work	9-3
9.4.1	Replacing the diaphragm	9-3
9.4.2	Replacing the actuator stem seals	9-7
9.5	Conversion work	9-9
9.5.1	Reversing the direction of action (fail-safe action)	9-9
9.6	Ordering spare parts and operating supplies	9-12
10	Decommissioning	10-1
11	Removal	11-1
11.1	Removing the actuator from the valve	11-2
11.2	Relieving the spring compression in the actuator	11-2
12	Repairs	12-1
12.1	Returning devices to SAMSON	12-1
13	Disposal	13-1
14	Certificates	14-1
15	Annex	15-1
15.1	Tightening torques, lubricants and tools	15-1
15.2	Spare parts	15-1
15.3	After-sales service	15-4

1 Safety instructions and measures

Intended use

The SAMSON Type 3271 and Type 3277 Actuators are designed for operating a mounted globe valve. In combination with the valve, the actuators are used to shut off the flow of liquids, gases or vapors in the pipeline. Depending on the version, the actuators are suitable for throttling or on/off service. The actuators can be used in processing and industrial plants.

The actuators are designed to operate under exactly defined conditions (e.g. thrust, travel). Therefore, operators must ensure that the actuators are only used in operating conditions that meet the specifications used for sizing the actuators at the ordering stage. In case operators intend to use the actuators in other applications or conditions than specified, contact SAMSON.

SAMSON does not assume any liability for damage resulting from the failure to use the device for its intended purpose or for damage caused by external forces or any other external factors.

→ Refer to the technical data and nameplate for limits and fields of application as well as possible uses.

Reasonably foreseeable misuse

The actuator is not suitable for the following applications:

- Use outside the limits defined during sizing and by the technical data
- Use outside the limits defined by the accessories connected to the actuator

Furthermore, the following activities do not comply with the intended use:

- Use of non-original spare parts
- Performing service and repair work not described

Qualifications of operating personnel

The actuator must be mounted, started up, serviced and repaired by fully trained and qualified personnel only; the accepted industry codes and practices must be observed. According to these mounting and operating instructions, trained personnel refers to individuals who are able to judge the work they are assigned to and recognize possible hazards due to their specialized training, their knowledge and experience as well as their knowledge of the applicable standards.

Safety instructions and measures

Personal protective equipment

We recommend wearing the following personal protective equipment when handling the Type 3271 and Type 3277 Pneumatic Actuators:

- Protective gloves and safety footwear when mounting or removing the actuator
 - Eye protection and hearing protection while the actuator is operating.
- ➔ Check with the plant operator for details on further protective equipment.

Revisions and other modifications

Revisions, conversions or other modifications of the product are not authorized by SAMSON. They are performed at the user's own risk and may lead to safety hazards, for example. Furthermore, the product may no longer meet the requirements for its intended use.

Safety devices

The Type 3271 and Type 3277 Actuators do not have any special safety equipment.

Warning against residual hazards

To avoid personal injury or property damage, plant operators and operating personnel must prevent hazards that could be caused in the actuator by the signal pressure, stored spring energy or moving parts by taking appropriate precautions. Plant operators and operating personnel must observe all hazard statements, warning and caution notes in these mounting and operating instructions.

Responsibilities of the operator

Operators are responsible for proper use and compliance with the safety regulations. Operators are obliged to provide these mounting and operating instructions as well as the referenced documents to the operating personnel and to instruct them in proper operation. Furthermore, operators must ensure that operating personnel or third parties are not exposed to any danger.

Responsibilities of operating personnel

Operating personnel must read and understand these mounting and operating instructions as well as the referenced documents and observe the specified hazard statements, warnings and caution notes. Furthermore, operating personnel must be familiar with the applicable health, safety and accident prevention regulations and comply with them.

Referenced standards, directives and regulations

According to the ignition risk assessment performed in accordance with Clause 5.2 of ISO 80079-36, the non-electrical actuators do not have their own potential ignition source even in the rare incident of an operating fault. As a result, they do not fall within the scope of Directive 2014/34/EU.

→ For connection to the equipotential bonding system, observe the requirements specified in Clause 6.4 of EN 60079-14 (VDE 0165-1).

Referenced documentation

The following documents apply in addition to these mounting and operating instructions:

- Mounting and operating instructions for the valve on which it is mounted
- Mounting and operating instructions for mounted valve accessories (positioner, solenoid valve etc.)
- Safety Manual ► SH 8310 for use in safety-instrumented systems
- ► AB 0100 for tools, tightening torques and lubricant

1.1 Notes on possible severe personal injury

DANGER

Risk of bursting in the actuator.

Actuators are pressurized. Improper opening can lead to actuator components bursting.

→ Before starting any work on the actuator, depressurize all plant sections affected and the actuator.

1.2 Notes on possible personal injury

WARNING

Crush hazard arising from moving parts.

The actuator contains moving parts (actuator stem), which can injure hands or fingers if inserted into the actuator.

- Do not touch the actuator stem or insert hands or finger into the yoke or beneath the actuator stem while the air supply is connected to the actuator.
- While working on the actuator, disconnect and lock the pneumatic air supply as well as the control signal.
- Do not impede the movement of the actuator stem by inserting objects into the yoke.
- Before unblocking the actuator stem after it has become blocked (e.g. due to seizing up after remaining in the same position for a long time), release any stored energy in the actuator (e.g. spring compression). See 'Relieving the spring compression in the actuator' in the 'Removal' section.

Risk of personal injury when the actuator vents.

The actuator is operated with air. As a result, air is vented during operation.

- Install the control valve in such a way that vent holes are not located at eye level and the actuator does not vent at eye level in the work position ¹⁾.
- Use suitable silencers and vent plugs.
- Wear eye and hearing protection when working near the actuator.

Risk of personal injury due to preloaded springs.

Actuators with preloaded springs are under tension. These actuators can be identified by several longer bolts with nuts protruding from the bottom diaphragm case. These bolts allow the spring compression to be relieved evenly on disassembling the actuator. Actuators with considerably preloaded springs are also labeled correspondingly (see the 'Markings on the device' section).

- Before starting any work on the actuator, relieve the compression from the preloaded springs. See 'Relieving the spring compression in the actuator' in the 'Removal' section.

¹⁾ If not described otherwise in the valve documentation, the work position for the control valve is the front view looking onto the operating controls (including valve accessories).

⚠ WARNING**Damage to health relating to the REACH regulation.**

If a SAMSON device contains a substance which is listed as being a substance of very high concern on the candidate list of the REACH regulation, this circumstance is indicated on the SAMSON delivery note.

- Information on safe use of the part affected, see
 - ▶ www.samsongroup.com > About SAMSON > Material Compliance > REACH.

Risk of personal injury through incorrect operation, use or installation as a result of information on the actuator being illegible.

Over time, markings, labels and nameplates on the actuator may become covered with dirt or become illegible in some other way. As a result, hazards may go unnoticed and the necessary instructions not followed. There is a risk of personal injury.

- Keep all relevant markings and inscriptions on the device in a constantly legible state.
- Immediately renew damaged, missing or incorrect nameplates or labels.

1.3 Notes on possible property damage

ⓘ NOTICE**Risk of actuator damage due to incorrectly attached slings.**

- Do not attach load-bearing slings to the handwheel or travel stop.

Risk of actuator damage due to excessively high or low tightening torques.

Observe the specified torques when tightening actuator components. Excessive tightening torques lead to parts wearing out more quickly. Parts that are not tightened far enough may loosen.

- Observe the specified tightening torques (▶ AB 0100).

Risk of actuator damage due to the use of unsuitable tools.

Certain tools are required to work on the actuator.

- Only use tools approved by SAMSON (▶ AB 0100).



NOTICE

Risk of actuator damage due to the use of unsuitable lubricants.

The lubricants to be used depend on the actuator material. Unsuitable lubricants may corrode and damage surfaces.

→ Only use lubricants approved by SAMSON (▶ AB 0100).

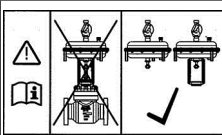
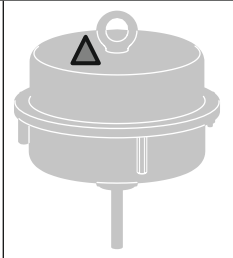

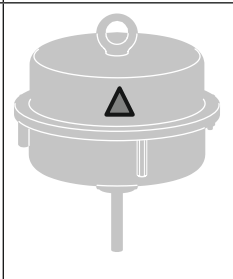
1.4 Warnings on the device

Warning	Meaning of the warning	Location on the device
	<p>Warning against the incorrect use of the lifting eyelet/eyebolt or swivel hoist on SAMSON actuators.</p> <p>Only attach load-bearing slings to them to vertically lift the actuator on its own (without the valve).</p> <p>The lifting eyelet/eyebolt and the swivel hoist must not be used to vertically lift the entire control valve assembly.</p>	
	<p>Warning to indicate that the springs in the actuator are preloaded.</p> <p>Actuators with preloaded springs are under tension. Incorrect opening of the actuator can lead to personal injury through the sudden and uncontrolled projection of parts.</p> <p>Before starting any work on the actuator, relieve the compression from the preloaded springs. See 'Relieving the spring compression in the actuator' in the 'Removal' section.</p>	

2 Markings on the device

2.1 Actuator nameplate

The nameplate is stuck on the diaphragm casing. It includes all details required to identify the device:

- 1 Type number
- 2 Country of origin
- 3 Material configuration number
- 4 Serial number
- 5 Actuator area
- 6 Bench range in bar
- 7 Bench range in psi
- 8 Operating travel in mm
- 9 Operating range in bar
- 10 Operating range in psi
- 11 Permissible supply pressure p_{max} in bar
- 12 Permissible supply pressure p_{max} in psi
- 13 Symbol indicating fail-safe action
 -  Actuator stem extends (FA)
 -  Actuator stem retracts (FE)
 -  Manual override
- 14 Diaphragm material
- 15 Connecting thread
- 16 Date of manufacture
- 17 Data Matrix code

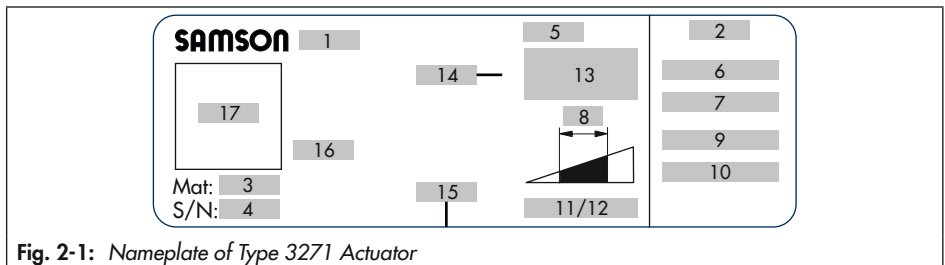

Fig. 2-1: Nameplate of Type 3271 Actuator

3 Design and principle of operation

The SAMSON Type 3271 and Type 3277 Actuators with 240, 350 and 700 cm² actuator areas are mounted to Series 240, 250, 280 and 290 Valves (globe valves).

The signal pressure p_{st} creates the force $F = p_{st} \cdot A$ at the diaphragm surface A which is opposed by the springs (A10) in the actuator. The bench range is determined by the number of springs used and their compression, taking into account the rated travel. The travel is proportional to the signal pressure p_{st} . The direction of action of the actuator stem (A7) depends on how the springs are installed in the actuator.

3.1 Type 3271

The actuator mainly consists of two diaphragm cases (A1, A2), the diaphragm (A4) with diaphragm plate (A5) and springs (A10) (see Fig. 3-1).

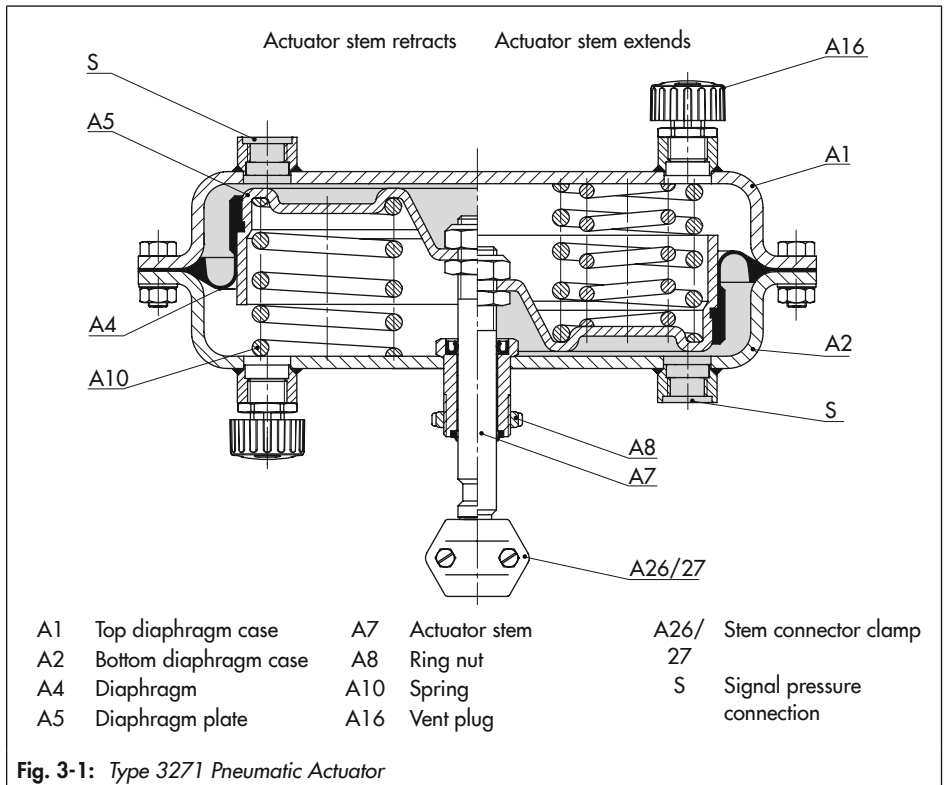

Design and principle of operation

Several springs may be fitted into one another.

The stem connector clamps (A26/27) connect the actuator stem (A7) with the plug stem of the globe valve.

3.2 Type 3277

The principle of operation is the same as that of the Type 3271 Actuator. The Type 3277 Actuator is fitted with an additional yoke on the bottom diaphragm case (A2) (see Fig. 3-2). The yoke allows the direct attachment of a positioner and/or limit switch. The benefit of this design is that the travel pick-off located inside the yoke is protected against external influences.

Refer to the mounting and operating instructions of the valve accessories to be mounted

for more details on their attachment and the accessories required.

3.3 Direction of action

The direction of action is determined by how the springs (A10) and diaphragm plate (A5) are arranged in the actuator.

With direction of action "actuator stem extends", the compressed air is applied to the signal pressure connection on the bottom diaphragm case.

With direction of action "actuator stem retracts", the compressed air is applied to the signal pressure connection on the top diaphragm case.

The direction of action can be reversed (see the 'Service and conversion work' section).

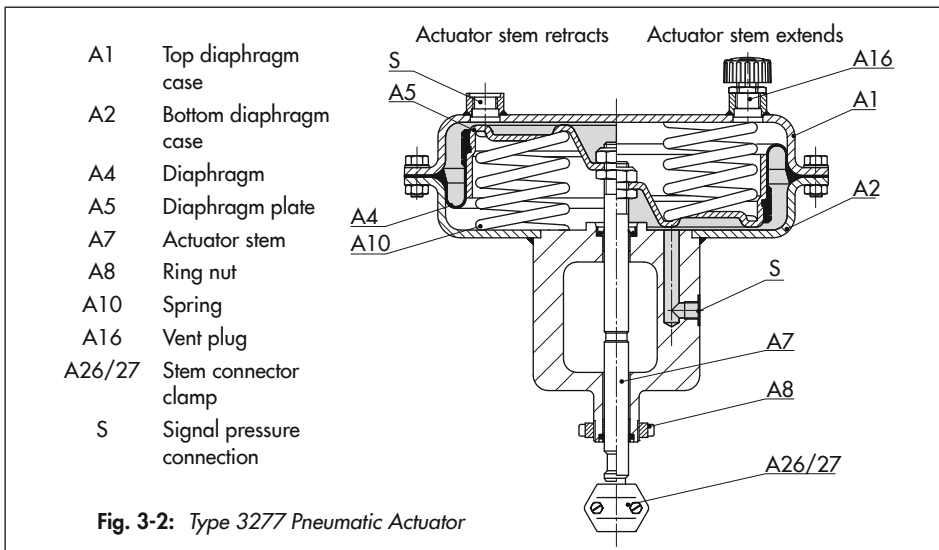

3.4 Signal pressure routing

3.4.1 Type 3271

In the "actuator stem extends" version, the signal pressure is routed through the bottom signal pressure connection (S) to the bottom diaphragm chamber and moves the actuator stem (A7) upward opposing the spring force (see Fig. 3-1, right).

In the "actuator stem retracts" version, the signal pressure is routed through the top signal pressure connection (S) to the top diaphragm chamber and moves the actuator stem (A7) downward opposing the spring force (see Fig. 3-1, left).

3.4.2 Type 3277

In the "actuator stem extends" version (see Fig. 3-2, right), a signal pressure connection (S) is located on the side of the yoke which is connected to the bottom diaphragm chamber over an internal hole. The signal pressure moves the actuator stem upward opposing the spring force. A positioner can be connected using a connection block at this point. No additional piping to the actuator is required. Refer to the associated positioner documentation for more details.

In the "actuator stem retracts" version, similar to Type 3271, the signal pressure is routed through the top signal pressure connection (S) to the top diaphragm chamber and moves the actuator stem (A7) downward opposing the spring force (see Fig. 3-2, left).

3.5 Fail-safe action

i Note

The listed fail-safe actions apply to SAMSON Series 240, 250, 280 and 290 Valves (globe valves).

When the signal pressure is reduced or the control signal fails, the fail-safe position of the control valve in throttling or on/off service depends on whether the springs are installed in the top or bottom diaphragm chamber.

Version with handwheel: in the active manual mode (the handwheel is not in the neutral position), the valve is not moved to the fail-safe position even upon failure of the supply air.

3.5.1 Actuator stem extends

When the signal pressure is reduced or the control signal fails, the springs move the actuator stem downward and close the globe valve. The valve opens when the signal pressure is increased enough to overcome the spring force.

3.5.2 Actuator stem retracts

When the signal pressure is reduced or the control signal fails, the springs move the actuator stem upward and open a mounted globe valve. The valve closes when the signal pressure is increased enough to overcome the spring force.

3.6 Versions

The Type 3271 and Type 3277 Pneumatic Actuators with 240, 350 or 700 cm² actuator area are available in the following versions:

- **Standard version**
The top and bottom diaphragm cases are made of painted sheet steel.
- **Corrosion-resistant version**
The top and bottom diaphragm cases are made of stainless sheet steel (1.4301).
- **Additional (top-mounted) handwheel**
The actuators can be fitted with an additional (top-mounted) handwheel (▶ T 8312).
- **Travel stop**
The actuators as a special version can be fitted with a mechanically adjustable travel stop. The travel is reduced by up to 50 % in both directions of action (stem extends or retracts).
- **Side-mounted handwheel**
The actuators can be combined with a Type 3273 Side-mounted Handwheel with max. 30 mm travel (▶ T 8312).

3.7 Accessories

Swivel hoist

The pneumatic actuators with 700 cm² actuator area have a female thread on the top diaphragm case to allow an eyebolt or swivel hoist to be screwed into it. The eyebolt can be used to vertically lift the actuator and is included in the scope of delivery. The swivel hoist is designed for setting a control valve

assembly upright or for lifting the actuator without valve. The swivel hoist can be ordered (accessories).

Actuator area	Item no.	
	Eyebolt (DIN 580)	Swivel hoist
700 cm ²	8325-0131	8442-1017

Lifting fixture for small actuators

A special lifting tool is available to lift pneumatic actuators with 240 and 350 cm² actuator areas (▶ AB 0100).

Vent plugs

Vent plugs are screwed into the exhaust air ports of pneumatic and electropneumatic devices. They ensure that any exhaust air that forms can be vented to the atmosphere (to avoid excess pressure in the device). Furthermore, the vent plugs allow air intake to prevent a vacuum from forming in the device.

▶ AB 07

Feedback connection (travel pick-off interface) according to IEC 60534-6-1

Various valve accessories according to IEC 60534-6-1 and NAMUR recommendation can be mounted on SAMSON control valves designed according to the modular principle. See associated valve documentation. The travel pick-off interface for these mounted devices can be ordered (accessories):

Type ... Actuator	Actuator area in cm ²	Item/material number (accessories) for	
		Attachment on one side	Attachment on both sides
3271	240	1400-6816 (included in scope of delivery of the actuator)	100029690
	350	100029695 (included in scope of delivery of the actuator)	1400-5529
	700		
3277	240	100029695	1400-5529
	350		
	700		

Temperature range

The permissible temperature range depends on the actuator service and diaphragm material:

Diaphragm material	Temperature range
Throttling service	
NBR	-35 to +90 °C -31 to +194 °F
EPDM	-50 to +120 °C -58 to +248 °F
On/off service	
NBR	-20 to +90 °C -4 to +194 °F
EPDM	-40 to +120 °C -40 to +248 °F

3.8 Technical data

The nameplate provides information on the actuator version (see the 'Markings on the device' section).

i Note

More information is available in Data Sheet
 ► T 8310-1.

Supply pressure

The maximum permissible supply pressure is specified in the order confirmation for the control valve. It is, however, restricted to 6 bar in throttling service. See the 'Operation' section for restrictions in on/off service.

Design and principle of operation

Dimensions in mm and weights in kg

Actuator	Type	3271			3277			
Actuator area	cm ²	240	350	700	240	350	700	
Height	H ¹⁾	–	–	134	–	–	135	
	H'	62	82	134	65	82	135	
	Ha	15	15	15	15	15	15	
	H1	Only with hand-wheel	300	320	490	400	420	590
		With handwheel and travel stop	400	420	590	500	520	690
	H2 _{max}	Only with hand-wheel	345	365	540	445	465	640
		With handwheel and travel stop	445	465	640	545	565	740
	H4 _{rated} FA	75	75	90	75	75	90	
	H4 _{max} FA	78	78	95	78	78	95	
	H4 _{max} FE	78	85	104	78	85	104	
	H5	–	–	–	101	101	101	
	H6	34	34	34	34	34	34	
	H7 ²⁾	–	–	65	–	–	65	
Travel limitation	H8	75	85	115	75	85	115	
Yoke width	L	–	–	–	70	70	70	
Diameter	ØD	240	280	390	240	280	390	
	ØD1	180	250	315	180	250	315	
	ØD2	10	16	16	16	16	16	
Ød (thread)		M30x1.5						
Air connection	a	G 1/4 (1/4 NPT)	G 3/8 (3/8 NPT)	G 3/8 (3/8 NPT)	G 1/4 (1/4 NPT)	G 3/8 (3/8 NPT)	G 3/8 (3/8 NPT)	
	a2	–	–	–	G 3/8	G 3/8	G 3/8	
Weight								
Without handwheel		5	8	22	9	12	26	
With handwheel		9	13	27	13	17	31	

1) In versions in which the lifting eyelet is welded directly onto the housing, H' and H are identical. The value H' applies.

2) Height of eyebolt according to DIN 580. Height of the swivel hoist may differ.

Dimensional drawings

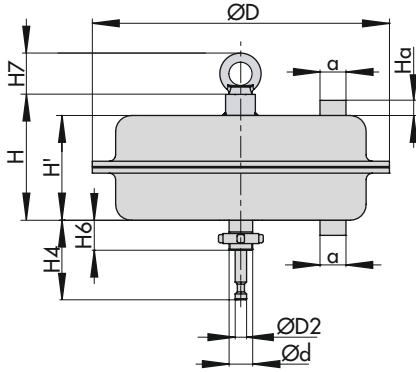

Standard version of Type 3271 (700 cm²)

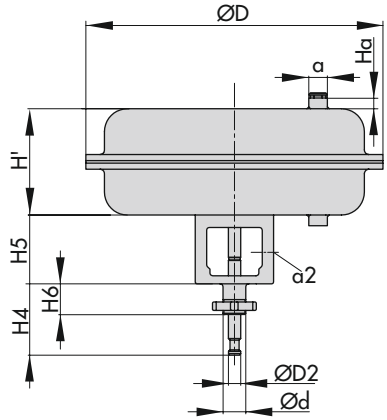

Standard version of Type 3277 (240, 350 cm²)

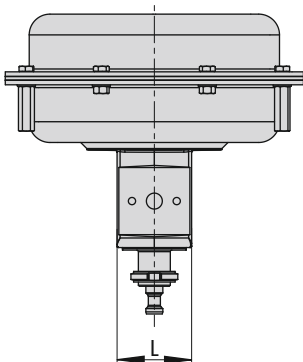

Type 3277 (side view)

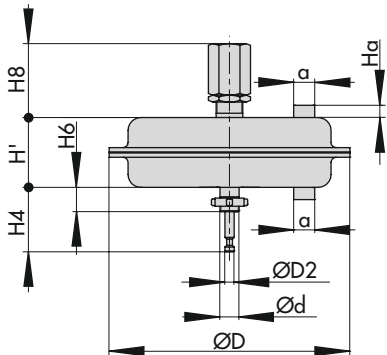

Type 3271 with travel stop

Design and principle of operation

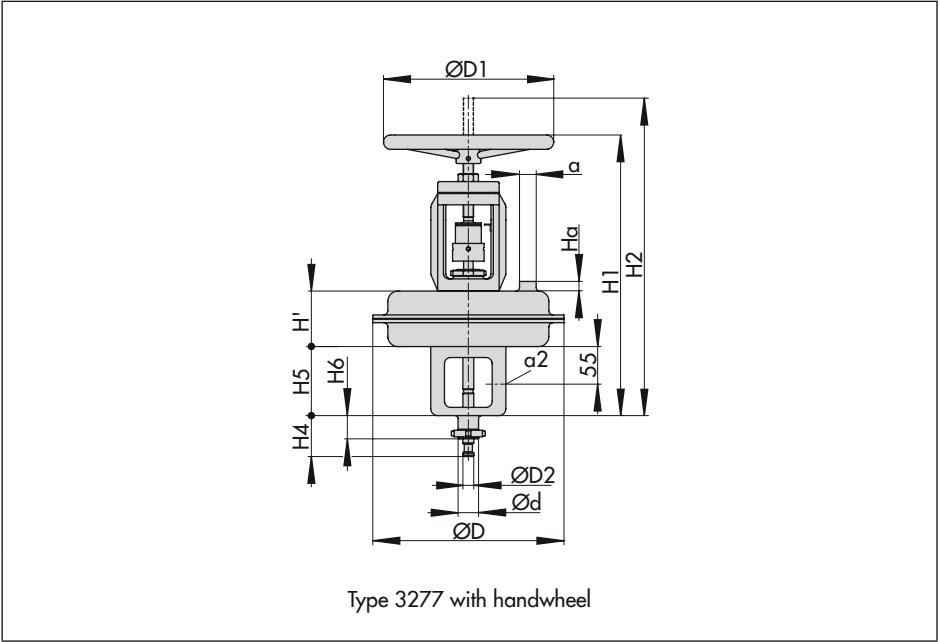

4 Shipment and on-site transport

The work described in this section is only to be performed by personnel appropriately qualified to carry out such tasks.

4.1 Accepting the delivered goods

After receiving the shipment, proceed as follows:

1. Check the scope of delivery. Check that the specifications on the actuator nameplate match the specifications in the delivery note. See the 'Markings on the device' section for nameplate details.
2. Check the shipment for transportation damage. Report any damage to SAMSON and the forwarding agent (refer to delivery note).
3. Determine the weight and dimensions of the units to be lifted and transported in order to select the appropriate lifting equipment and lifting accessories. Refer to the transport documents and the 'Technical data' section.

4.2 Removing the packaging from the actuator

Observe the following sequence:

- Do not open or remove the packaging until immediately before mounting the actuator.

- Leave the actuator in its transport container or on the pallet to transport it on site.
- Dispose and recycle the packaging in accordance with the local regulations.

4.3 Transporting and lifting the actuator

⚠ DANGER

Danger due to suspended loads falling.

- *Stay clear of suspended or moving loads.*
 - *Close off and secure the transport paths.*
-

⚠ WARNING

Risk of lifting equipment tipping over and risk of damage to lifting accessories due to exceeding the rated lifting capacity.

- *Only use approved lifting equipment and accessories whose minimum lifting capacity is higher than the weight of the actuator (including the packaging, if applicable).*
-

ⓘ NOTICE

Risk of actuator damage due to incorrectly attached slings.

700 cm² actuator: the lifting eyelet/eyebolt or swivel hoist on the top diaphragm case is only intended for mounting and removing the actuator as well as lifting the actuator without the valve. The lifting eyelet/eyebolt and the swivel hoist must not be used to

Shipment and on-site transport

vertically lift the entire control valve assembly.

- Do not attach load-bearing slings to the handwheel or travel stop.
- Observe lifting instructions (see section 4.3.2).



Tip

Our after-sales service can provide more detailed transport and lifting instructions on request.

4.3.1 Transporting the actuator

The actuator can be transported using lifting equipment (e.g. crane or forklift).

- Leave the actuator in its transport container or on the pallet to transport it.
- Observe the transport instructions.

Transport instructions

- Protect the actuator against external influences (e.g. impact).
- Do not damage the corrosion protection (paint, surface coatings). Repair any damage immediately.
- Protect the actuator against moisture and dirt.
- Observe permissible temperatures (see 'Technical data' in the 'Design and principle of operation' section).

4.3.2 Lifting the actuator

To mount large actuators onto the valve, use lifting equipment (e.g. crane or forklift) to lift it. See 'Accessories' in the 'Design and principle of operation' section for fixture for lifting.

Lifting instructions

- Use a hook with safety latch (see Fig. 4-5) to secure the slings from slipping off the hook during lifting and transporting.
- Secure slings on the object to be transported against slipping.
- Make sure the slings can be removed from the actuator once it has been mounted on the valve.
- Prevent the actuator from tilting or tipping.
- Do not leave loads suspended when interrupting work for longer periods of time.

a) Lifting the actuator (without valve)

1. 700 cm² actuator: open the eyebolt cover by lightly pressing the side clips (see Fig. 4-3 and Fig. 4-4).
2. 700 cm² actuator: attach a sling to the lifting eyelet/eyebolt or swivel hoist of the actuator and to the rigging equipment (e.g. hook) of the crane or forklift (see Fig. 4-5).

3. Carefully lift the actuator. Check whether the lifting equipment and accessories can bear the weight.
4. Move the actuator at an even pace to the mounting site.
5. Mount the actuator onto the valve (see the 'Installation' section).
6. Remove slings after mounting.
700 cm² actuator: replace the cover on the eyebolt (see Fig. 4-4 and Fig. 4-3).

b) Lifting the entire control valve assembly

A swivel hoist can be screwed into versions with a female thread on the top diaphragm case of the actuator in place of the eyebolt (see 'Accessories' in the 'Design and principle of operation' section). In contrast to the eyebolt, the swivel hoist may be used for setting a control valve assembly upright.

In order to lift an entire control valve assembly, the slings attached to the valve body must bear the entire load. The sling between the lashing point on the actuator and rigging equipment (hook, shackle etc.) must not bear any load. The sling only protects the control valve from tilting while being lifted. Before lifting the control valve, tighten the sling.

- See associated valve documentation for instructions on how to lift a control valve.

Shipment and on-site transport



Fig. 4-1: Ring bolt

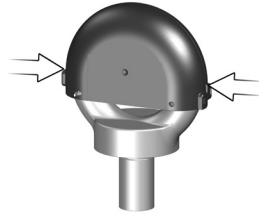

Fig. 4-3: Eyebolt cover in place on the eyebolt

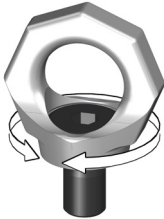

Fig. 4-2: Swivel hoist

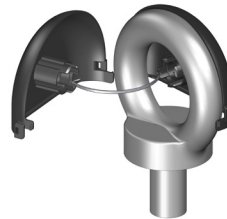

Fig. 4-4: Eyebolt cover (with strap) opened

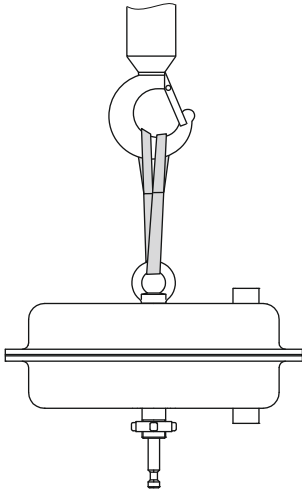

Fig. 4-5: Lifting point on the actuator

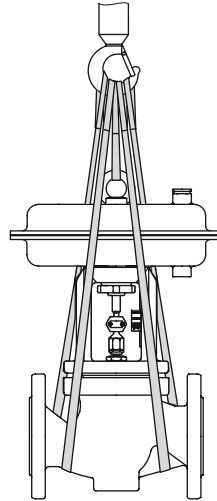

Fig. 4-6: Lifting points on the control valve (example)

4.4 Storing the actuator

NOTICE

Risk of actuator damage due to improper storage.

- *Observe the storage instructions.*
- *Avoid long storage times.*
- *Contact SAMSON in case of different storage conditions or longer storage times.*

Note

We recommend regularly checking the actuator and the prevailing storage conditions during long storage times.

Storage instructions

- When the valve and actuator are already assembled, observe the storage conditions for control valves. See associated valve documentation.
- Protect the actuator against external influences (e.g. impact).
- Secure the actuator in the stored position against slipping or tipping over.
- Do not damage the corrosion protection (paint, surface coatings). Repair any damage immediately.
- Protect the actuator against moisture and dirt. Store it at a relative humidity of less than 75 %. In damp spaces, prevent condensation. If necessary, use a drying agent or heating.

- Make sure that the ambient air is free of acids or other corrosive media.
- Observe permissible temperatures (see 'Technical data' in the 'Design and principle of operation' section).
- Do not place any objects on the actuator.

Special storage instructions for elastomers

Elastomer, e.g. actuator diaphragm

- To keep elastomers in shape and to prevent cracking, do not bend them or hang them up.
- We recommend a storage temperature of 15 °C for elastomers.
- Store elastomers away from lubricants, chemicals, solutions and fuels.

Tip

Our after-sales service can provide more detailed storage instructions on request.

5 Installation

The work described in this section is only to be performed by personnel appropriately qualified to carry out such tasks.

5.1 Preparation for installation

Before installation, make sure the following conditions are met:

- The actuator is not damaged.
- The type designation, material and temperature range of the actuator match the ambient conditions (temperatures etc.). See the 'Markings on the device' section for nameplate details.

Proceed as follows:

- ➔ Lay out the necessary material and tools to have them ready during mounting.
- ➔ Check that the vent plugs to be used are not blocked.
- ➔ Check any pressure gauges mounted on valve accessories to make sure they function properly.
- ➔ When the valve and actuator are already assembled, check the tightening torques of the bolted joints (▶ AB 0100). Components may loosen during transport.

5.2 Mounting the device

Depending on the version, SAMSON control valves are either delivered with the actuator already mounted on the valve or the valve and actuator are delivered separately. When delivered separately, the valve and actuator

must be assembled together on site. Proceed as follows to mount the actuator and before start-up.

⚠ WARNING

Risk of personal injury due to exhaust air being vented.

The actuator is operated with air. As a result, air is vented during operation.

- ➔ *During mounting make sure that vent holes are not located at eye level in the work position of the control valve and the actuator does not vent at eye level in the work position.*
 - ➔ *Wear eye and hearing protection when working near the actuator.*
-

⚠ WARNING

Crush hazard arising from the moving actuator stem.

- ➔ *Do not touch the actuator stem or insert hands or finger into the yoke while the air supply is connected to the actuator.*
 - ➔ *Before working on the actuator, disconnect and lock the pneumatic air supply as well as the control signal.*
 - ➔ *Do not impede the movement of the actuator stem by inserting objects into the yoke.*
 - ➔ *Before unblocking the actuator stem after it has become blocked (e.g. due to seizing up after remaining in the same position for a long time), release any stored energy in the actuator (e.g. spring compression). See 'Relieving the spring compression in the actuator' in the 'Removal' section.*
-

NOTICE

Risk of actuator damage due to excessively high or low tightening torques.

Observe the specified torques when tightening actuator components. Excessive tightening torques lead to parts wearing out more quickly. Parts that are not tightened far enough may loosen.

→ Observe the specified tightening torques (▶ AB 0100).

NOTICE

Risk of actuator damage due to the use of unsuitable tools.

→ Only use tools approved by SAMSON (▶ AB 0100).

5.2.1 Mounting the actuator onto the valve

NOTICE

Risk of valve damage or malfunction due to an incorrectly aligned V-port plug.

On mounting the actuator onto valves fitted with a V-port plug, make sure that the V-shaped port uncovered first faces toward the valve outlet.

→ Read the 'Mounting the actuator onto the valve' section in the associated valve documentation.

Tip

The valve and actuator are assembled with special attention paid to the actuator's bench range and direction of action. These details are specified on the actuator nameplate (see the 'Markings on the device' section).

a) Valve version without anti-rotation fixture

1. Loosen the lock nut (10) and stem connector nut (9) on the valve.
2. Firmly press the plug together with the plug stem into the seat ring.
3. Thread down the lock nut and stem connector nut.
4. Remove the clamps of the stem connector (A26/A27) and the ring nut (A8) from the actuator.
5. Slide the ring nut over the plug stem.
6. Place the actuator onto the valve bonnet (2) and secure it with the ring nut.
7. Connect the signal pressure. See section 5.2.2.
8. Screw on the stem connector nut (9) by hand until it touches the actuator stem (A7).
9. Turn the stem connector nut a further quarter turn and secure this position with the lock nut (10).
10. Position the stem connector clamps (A26/A27) and screw them tight.

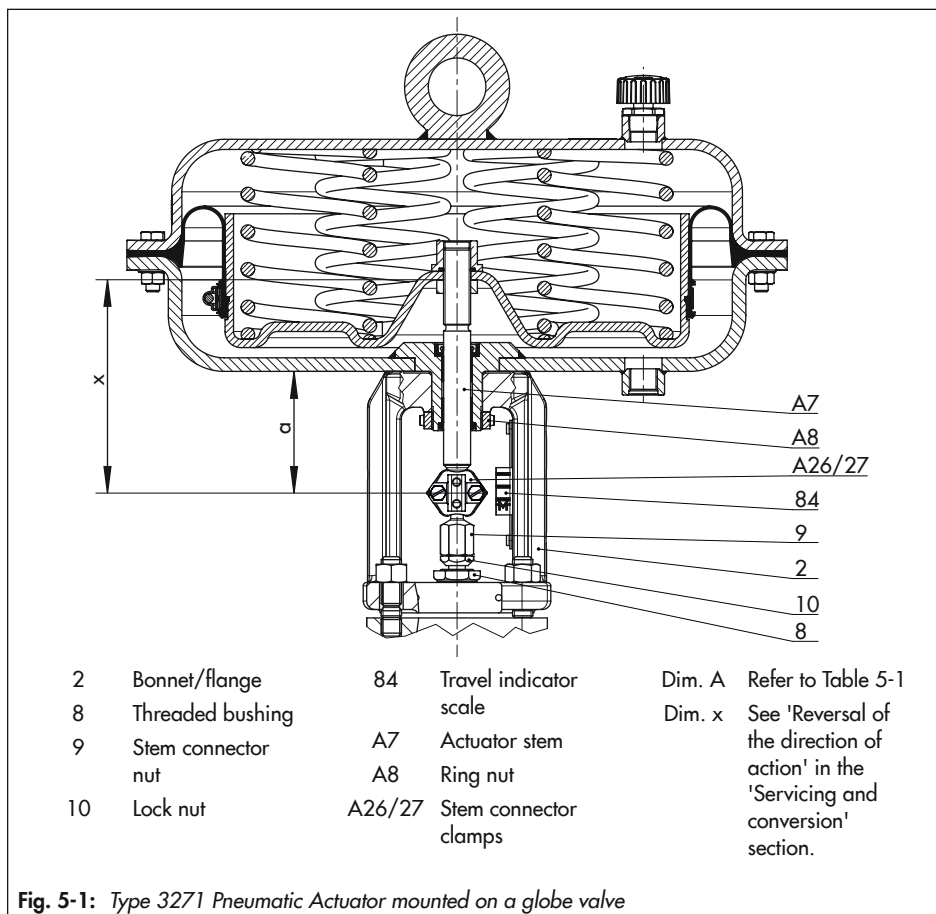

Fig. 5-1: Type 3271 Pneumatic Actuator mounted on a globe valve

11. Make sure that the dimension *a* is adjusted as specified in Table 5-1.
12. Align the travel indicator scale (84) with the tip of the stem connector clamp.

Table 5-1: Values for dimension x ¹⁾ (see Fig. 5-1)

Actuator area	Travel in mm	Dimension a in mm
240	0 (0 %)	75
	15 (100 %)	60
	17 (112.5 %)	58
350	0 (0 %)	75
	15 (100 %)	60
	19 (125 %)	53
700	0 (0 %)	90
	30 (100 %)	60
	38 (125 %)	52

¹⁾ Type 3271: bottom edge of the bottom case to the top of the actuator stem
 Type 3277: bottom edge of the bottom case to the top of the actuator stem

b) Valve version with anti-rotation fixture

1. Firmly press the plug together with the plug stem into the seat ring.

2. **Anti-rotation fixture not yet mounted onto the valve:**

Follow the instructions described under 'Mounting the external anti-rotation fixture' in the associated valve documentation up to the point where the actuator is to be mounted.

Anti-rotation fixture already mounted onto the valve:

Slightly loosen the screws (303) and turn the stem (9) inside the stem connector clamps (301) by a few turns to move it downward.

3. Remove the clamps of the stem connector (A26) and the ring nut (A8) from the actuator.
4. Slide the ring nut over the plug stem.
5. Place the actuator onto the valve bonnet (2) and secure it with the ring nut.
6. Connect the signal pressure. See section 5.2.2.
7. Continue following the instructions described under 'Mounting the external anti-rotation fixture' in the associated valve documentation from the point where the stem (9) is threaded upwards until the head of the stem rests on the extended actuator stem.
8. Align and fasten the travel indicator scale as described in the 'Mounting the actuator onto the valve' section in the associated valve documentation.

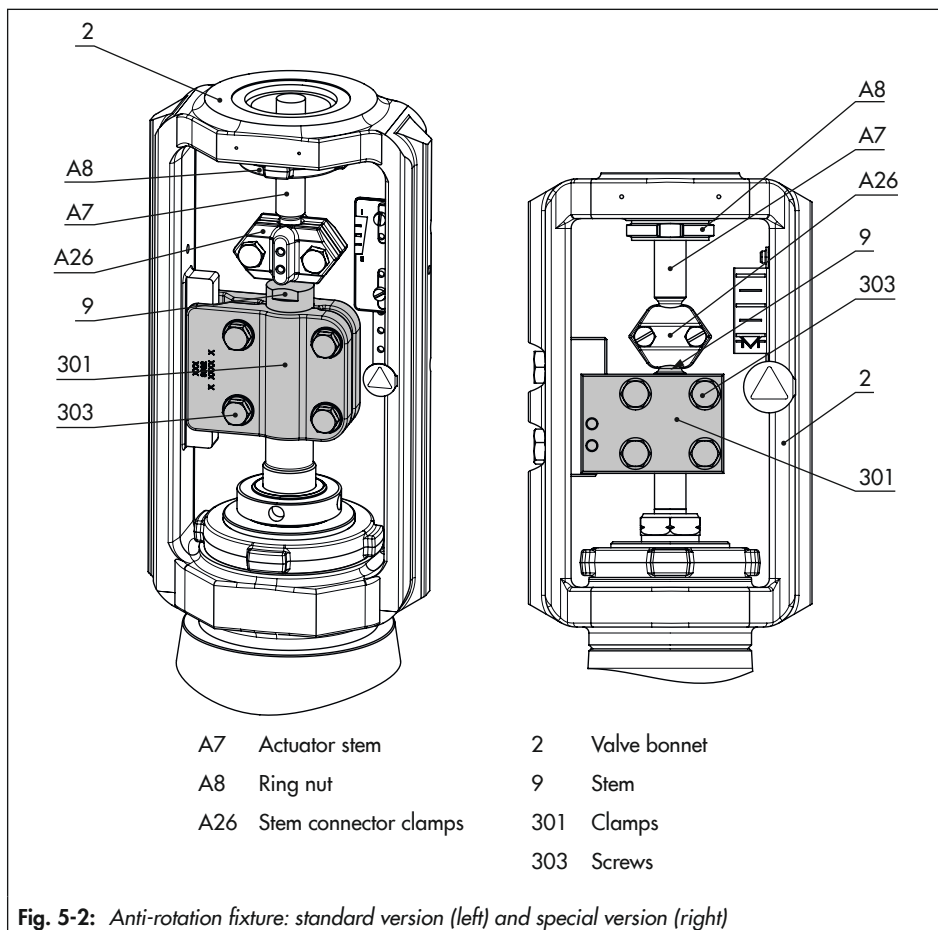

5.2.2 Connecting the air supply

Determine the lower and upper signal pressure range values before connecting the supply air:

- The lower signal pressure range value is the same as the minimum value of the bench range or operating range (with preloaded springs).
- The upper signal pressure range value is the same as the maximum value of the bench range or operating range (with preloaded springs).
- For actuator springs that are to be preloaded subsequently, determine the upper and lower signal pressure range as described under 'Spring compression' in the 'Start-up' section.

a) Actuator stem extends

1. Apply a signal pressure that corresponds to the lower signal pressure range value to the connection on the bottom diaphragm case.
2. Screw the vent plug into the connection on the top diaphragm case.

b) Actuator stem retracts

1. Apply a signal pressure that corresponds to the upper signal pressure range value to the connection on the top diaphragm case.
2. Screw the vent plug into the connection on the bottom diaphragm case.

6 Start-up

The work described in this section is only to be performed by personnel appropriately qualified to carry out such tasks.

⚠ DANGER

Risk of bursting due to incorrect opening of pressurized equipment or components.

Pneumatic actuators are pressure equipment that may burst when handled incorrectly.

Flying projectile fragments or components can cause serious injury or even death.

Before working on the actuator:

- Depressurize all plant sections concerned and the actuator. Release any stored energy.

⚠ WARNING

Risk of personal injury due to preloaded springs.

Actuators with preloaded springs are under tension. These actuators can be identified by several longer bolts with nuts protruding from the bottom diaphragm case. Actuators with considerably preloaded springs are also labeled correspondingly (see the 'Markings on the device' section).

- Only open the actuator following the instructions in this document. See 'Relieving the spring compression in the actuator' in the 'Removal' section.

⚠ WARNING

Risk of personal injury due to exhaust air being vented.

The actuator is operated with air. As a result, air is vented during operation.

- Wear eye and hearing protection when working near the actuator.

⚠ WARNING

Crush hazard arising from the moving actuator stem.

- Do not insert hands or finger into the yoke while the air supply is connected to the actuator.
- Before working on the actuator, disconnect and lock the pneumatic air supply as well as the control signal.
- Do not impede the movement of the actuator stem by inserting objects into the yoke.
- Before unblocking the actuator stem after it has become blocked (e.g. due to seizing up after remaining in the same position for a long time), release any stored energy in the actuator (e.g. spring compression). See 'Relieving the spring compression in the actuator' in the 'Removal' section.

⚠ WARNING

Risk of personal injury through incorrect operation, use or installation as a result of incorrect information on the actuator.

After any adjustment or conversion work, the details on the actuator nameplate may no

Start-up

longer be correct. This may apply, for example, to the configuration ID or the symbol after reversal of the direction of action.

- Immediately renew any nameplates or labels with incorrect or outdated information.
- Add any new values to the nameplate. If necessary, contact SAMSON to obtain a new nameplate.

NOTICE

Risk of actuator damage due to excessively high or low tightening torques.

Observe the specified torques when tightening actuator components. Excessive tightening torques lead to parts wearing out more quickly. Parts that are not tightened far enough may loosen.

- Observe the specified tightening torques (▶ AB 0100).

NOTICE

Risk of actuator damage due to the use of unsuitable tools.

- Only use tools approved by SAMSON (▶ AB 0100).

6.1 Spring compression

Refer to Fig. 6-1

By preloading the springs in the actuator, the following can be achieved:

- The thrust is increased (only actuators with "stem extends")

- In combination with a SAMSON valve: the actuator travel range can be adapted to a smaller valve travel range

6.1.1 Tensioning the springs

NOTICE

Risk of actuator damage due to the springs being tensioned unevenly.

- Distribute clamping bolts and nuts evenly around the circumference.
- Tighten the nuts gradually in a crisscross pattern.

1. Distribute the long bolts (A22) evenly around the circumference.
2. Screw the long nuts (A23) together with washers (A25) onto the clamping bolts (A22) until they rest on the bottom diaphragm case (A2).
3. To tension the springs evenly, tighten the nuts (A23) gradually in a crisscross pattern until both diaphragm cases (A1, A2) rest on the diaphragm (A4). Hold the bolt head stationary with a suitable tool and apply the tightening torque to the nuts. Observe tightening torques.
4. Insert the short bolts (A20) through the intended holes in the diaphragm cases (A1, A2).

- Screw the short nuts (A21) with washers (A25) onto the bolts (A20). Observe tightening torques.

6.1.2 Increasing the actuator thrust

The thrust can only be increased in actuators with "stem extends" direction of action. To achieve this, the springs of the actuators can be preloaded by up to 12.5 % (240 cm²) or by up to 25 % (350 and 700 cm²) of their travel or bench range.

Example: Preloading is required for a bench range of 0.4 to 2 bar. 25 % of this span is 0.4 bar. Therefore, the signal pressure range is shifted by 0.4 bar to 0.8 to 2.4 bar. The new lower signal range value is 0.8 bar and the new upper signal range value 2.4 bar.

→ Write the new signal pressure range of 0.8 to 2.4 bar on the actuator nameplate as the operating range with preloaded springs.

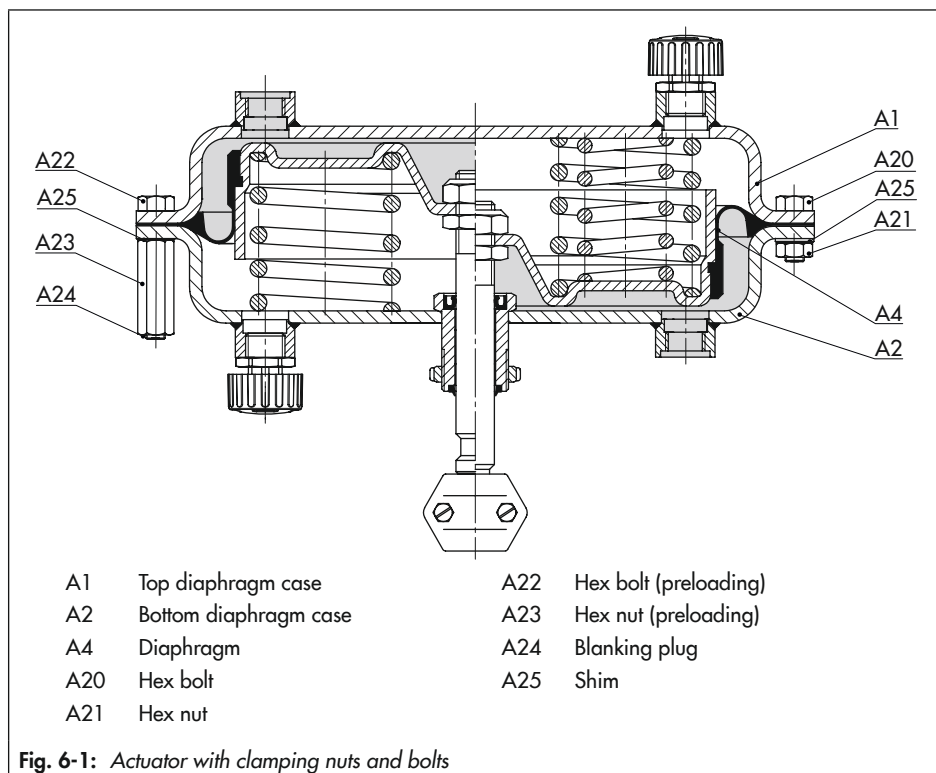

6.1.3 Adapting the travel range

In some cases, the valve and actuator have different rated travels. Depending on the direction of action, proceed as follows:

Direction of action: actuator stem extends

Always use actuators with preloaded springs when the valve's rated travel is smaller than the rated travel of the actuator.

Example: DN 50 valve with 15 mm rated travel and 700 cm² actuator with 30 mm rated travel; 0.4 to 2 bar bench range.

The signal pressure for half the actuator travel (15 mm) is 1.2 bar. Adding it to the lower signal pressure range value of 0.4 bar results in a signal pressure of 1.6 bar required for spring compression. The new lower signal range value is 1.6 bar and the new upper signal range value 2.4 bar.

→ Write the new signal pressure range of 1.6 to 2.4 bar on the actuator nameplate as the operating range with preloaded springs.

Direction of action: actuator stem retracts

The springs of actuators with "stem retracts" action cannot be preloaded. When a SAMSON valve is combined with an oversized actuator (e.g. the rated travel of the actuator is larger than the rated travel of the valve), only the first half of the actuator's bench range can be used.

Example: DN 50 valve with 15 mm rated travel and 700 cm² actuator with 30 mm rated travel; 0.2 to 1 bar bench range.

At half the valve travel, the operating range is between 0.2 and 0.6 bar.

6.2 Travel stop

Refer to Fig. 6-2

In the version with travel stop, the maximum and minimum actuator travel can be limited as follows:

Direction of action	Min. stop	Max. stop
Stem extends (FA)	0...125 %	50...125 %
Stem retracts (FE)	0...100 %	50...100 %

6.2.1 Bottom travel stop (minimum travel)

1. Loosen top lock nut (A74) and unscrew cover (A73).
2. Loosen bottom lock nut (A74) and turn the adjustment nut (A70) to adjust the travel stop.
3. Tighten bottom lock nut (A74).
4. Attach cover (A73) and retighten lock nut (A74).

6.2.2 Top travel stop (maximum travel)

1. Loosen top lock nut (A74).
2. Adjust the cover (A73) to the required travel stop.
3. Retighten top lock nut (A74).

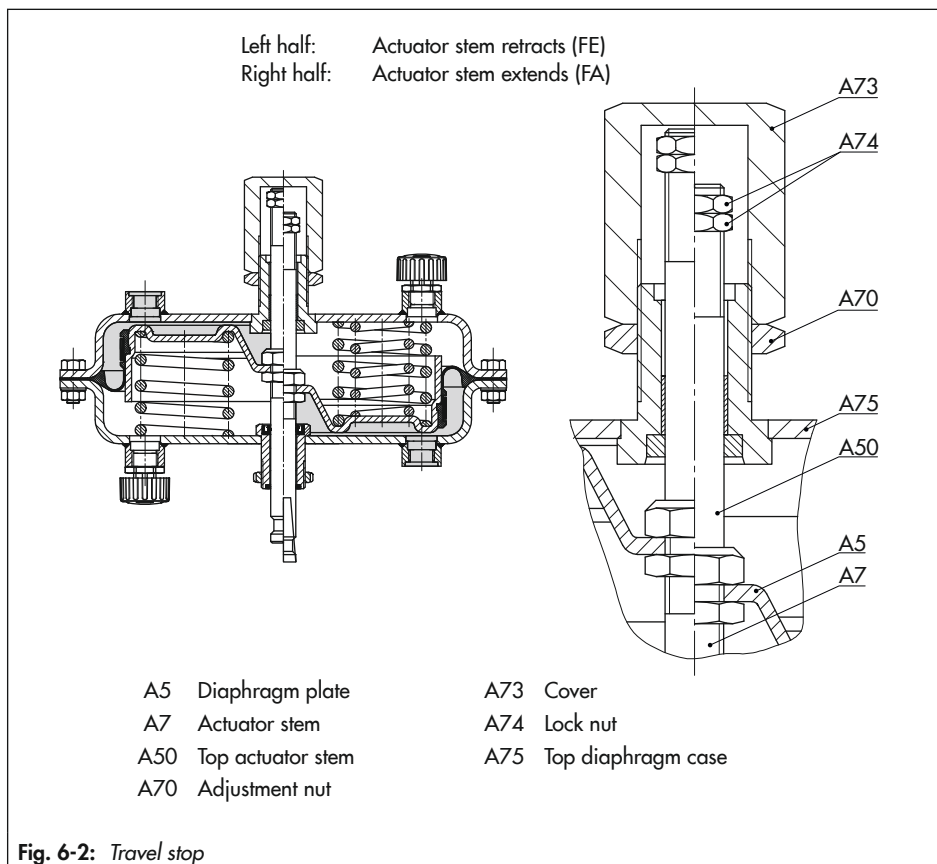

6.3 Version with handwheel

See Fig. 6-3

The stem connector (A51) connects the actuator stem (A7) with the actuator stem (A50) of the handwheel. The actuator stem position can be adjusted using the handwheel (A60).

i Note

Contact our after-sales service to retrofit an actuator with a handwheel.

6.3.1 Extending the actuator stem manually

1. Loosen the lock nut (A66) to unlock the handwheel (A60).
2. Turn the handwheel clockwise to extend the actuator stem.
3. To change from manual to automatic operation, put the handwheel into the neutral position by aligning the pointer (A55) with the groove on the stem connector (A51).
4. Tighten the lock nut (A66) to lock the handwheel.

6.3.2 Retracting the actuator stem manually

1. Loosen the lock nut (A66) to unlock the handwheel (A60).
2. Turn the handwheel counterclockwise to retract the actuator stem.
3. To change from manual to automatic operation, put the handwheel into the neutral position by aligning the pointer (A55) with the groove on the stem connector (A51).
4. Tighten the lock nut (A66) to lock the handwheel.

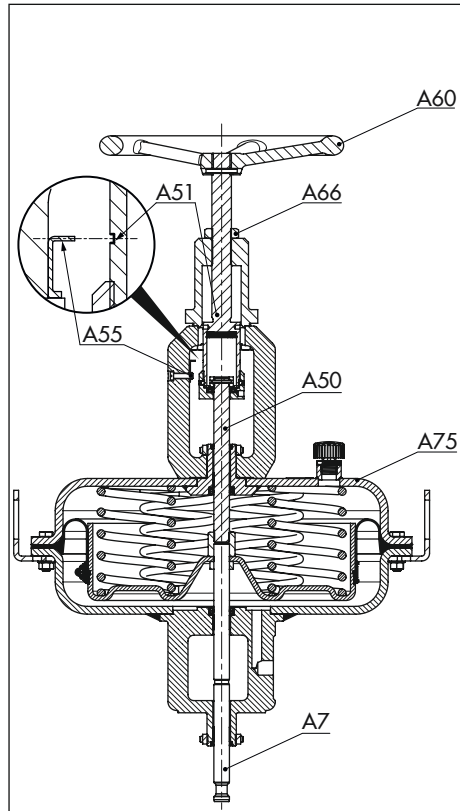

- A7 Actuator stem
- A50 Top actuator stem
- A51 Stem connector
- A55 Pointer
- A60 Handwheel
- A66 Lock nut
- A75 Top diaphragm case

Fig. 6-3: Pneumatic actuator with handwheel

7 Operation

The work described in this section is only to be performed by personnel appropriately qualified to carry out such tasks.

⚠ WARNING

Risk of personal injury due to exhaust air being vented.

The actuator is operated with air. As a result, air is vented during operation.

- Wear eye and hearing protection when working near the actuator.

⚠ WARNING

Crush hazard arising from the moving actuator stem.

- Do not insert hands or finger into the yoke while the air supply is connected to the actuator.
- Before working on the actuator, disconnect and lock the pneumatic air supply as well as the control signal.
- Do not impede the movement of the actuator stem by inserting objects into the yoke.
- Before unblocking the actuator stem after it has become blocked (e.g. due to seizing up after remaining in the same position for a long time), release any stored energy in the actuator (e.g. spring compression). See 'Relieving the spring compression in the actuator' in the 'Removal' section.

⚠ WARNING

Risk of personal injury through incorrect operation, use or installation as a result of incorrect information on the actuator.

After any adjustment or conversion work, the details on the actuator nameplate may no longer be correct. This may apply, for example, to the configuration ID or the symbol after reversal of the direction of action.

- Immediately renew any nameplates or labels with incorrect or outdated information.
- Add any new values to the nameplate. If necessary, contact SAMSON to obtain a new nameplate.

7.1 Throttling service

The maximum permissible supply pressure is specified in the order confirmation for the control valve. It is, however, restricted to 6 bar in throttling service for the Types 3271 and Type 3277 Pneumatic Actuators with 240, 350 and 700 cm² actuator areas.

7.2 On/off service

In on/off service, the supply pressure must be limited depending on the bench range or operating range of the actuator. The applicable bench range or operating range which the actuator can move through is written on the nameplate (see the 'Markings on the device' section).

Operation

Actuator stem retracts (FE)

For the direction of action "actuator stem retracts", the permissible supply pressure must not exceed the upper bench range value by more than 3 bar:

Rated signal range	Fail-safe action	Max. supply pressure
0.2 to 1.0 bar	Actuator stem retracts	4 bar
0.4 to 2.0 bar		5 bar
0.6 to 3.0 bar		6 bar

Actuator stem extends (FA)

With direction of action "actuator stem extends" and travel stop, the supply pressure must not exceed the upper bench range value by more than 1.5 bar.

7.3 Manual mode (versions with handwheel only)

In the manual mode, the valve is opened and closed by the handwheel. The valve position is independent of the signal pressure or actuator springs.

The handwheel must be in the neutral position to allow the actuator to move through its entire travel range in throttling or on/off service.

In Type 3271 and Type 3277 Pneumatic Actuators with 700 cm² actuator area and a handwheel, the upper bench range value must not exceed 3.3 bar.

7.4 Additional notes concerning operation

- Label actuator with reduced supply pressure with a sticker ("Max. supply pressure limited to ... bar").
- Only apply the signal pressure to the signal pressure connection (S) on the diaphragm chamber of the actuator which does not contain any springs (see Fig. 3-1 and Fig. 3-2 in the 'Design and principle of operation' section).
- Only use vent plugs that let air through them (A16 in Fig. 3-1 and Fig. 3-2 in the 'Design and principle of operation' section).

8 Malfunctions

Read hazard statements, warnings and caution notes in the 'Safety instructions and measures' section.

8.1 Troubleshooting

Malfunction	Possible reasons	Recommended action
Actuator stem does not move on demand.	Actuator is blocked.	Check attachment. Remove the blockage. WARNING! A blocked actuator (e.g. due to seizing up after remaining in the same position for a long time) can suddenly start to move uncontrollably. Injury to hands or fingers is possible if they are inserted into the actuator or valve. Before trying to unblock the actuator stem, disconnect and lock the pneumatic air supply as well as the control signal. Before unblocking the actuator stem, release any stored energy in the actuator (e.g. spring compression). See 'Relieving the spring compression in the actuator' in the 'Removal' section.
	Insufficient signal pressure	Check the signal pressure. Check the signal pressure line for leakage.
	Signal pressure not connected to the correct diaphragm chamber.	See 'Signal pressure routing' in the 'Design and principle of operation' section.
	Diaphragm in the actuator defective	See 'Replacing the diaphragm' in the 'Servicing' section.
Actuator stem does not stroke through its complete travel range.	Travel stop active	See 'Adjusting the travel stop' in the 'Start-up' section.
	Insufficient signal pressure	Check the signal pressure. Check the signal pressure line for leakage.
	Incorrect setting of valve accessories.	Check the actuator without valve accessories. Check the settings of the valve accessories.

i Note

Contact our after-sales service for malfunctions not listed in the table.

8.2 Emergency action

Plant operators are responsible for emergency action to be taken in the plant.

9 Servicing and conversion

The work described in this section is only to be performed by personnel appropriately qualified to carry out such tasks.

The following documents are also necessary for servicing the valve:

- ► AB 0100 for tools, tightening torques and lubricant

⚠ DANGER

Risk of bursting due to incorrect opening of pressurized equipment or components.

Pneumatic actuators are pressure equipment that may burst when handled incorrectly.

Flying projectile fragments or components can cause serious injury or even death.

Before working on the actuator:

- Depressurize all plant sections concerned and the actuator. Release any stored energy.

⚠ WARNING

Risk of personal injury due to preloaded springs.

Actuators with preloaded springs are under tension. These actuators can be identified by several longer bolts with nuts protruding from the bottom diaphragm case. Actuators with considerably preloaded springs are also labeled correspondingly (see the 'Markings on the device' section).

- Only open the actuator following the instructions in this document. See 'Relieving the spring compression in the actuator' in the 'Removal' section.

⚠ WARNING

Risk of personal injury due to exhaust air being vented.

The actuator is operated with air. As a result, air is vented during operation.

- Wear eye and hearing protection when working near the actuator.

⚠ WARNING

Crush hazard arising from the moving actuator stem.

- Do not insert hands or finger into the yoke while the air supply is connected to the actuator.
- Before working on the actuator, disconnect and lock the pneumatic air supply as well as the control signal.
- Do not impede the movement of the actuator stem by inserting objects into the yoke.
- Before unblocking the actuator stem after it has become blocked (e.g. due to seizing up after remaining in the same position for a long time), release any stored energy in the actuator (e.g. spring compression). See 'Relieving the spring compression in the actuator' in the 'Removal' section.

⚠ WARNING

Risk of personal injury through incorrect operation, use or installation as a result of incorrect information on the actuator.

After any adjustment or conversion work, the details on the actuator nameplate may no

Servicing and conversion

longer be correct. This may apply, for example, to the configuration ID or the symbol after reversal of the direction of action.

- Immediately renew any nameplates or labels with incorrect or outdated information.
- Add any new values to the nameplate. If necessary, contact SAMSON to obtain a new nameplate.

NOTICE

Risk of actuator damage due to excessively high or low tightening torques.

Observe the specified torques when tightening actuator components. Excessive tightening torques lead to parts wearing out more quickly. Parts that are not tightened far enough may loosen.

- Observe the specified tightening torques (▶ AB 0100).

NOTICE

Risk of actuator damage due to the use of unsuitable tools.

- Only use tools approved by SAMSON (▶ AB 0100).

NOTICE

Risk of valve damage due to the use of unsuitable lubricants.

- Only use lubricants approved by SAMSON (▶ AB 0100).

Note

- The product warranty becomes void if service or repair work not described in these instructions is performed without prior agreement by SAMSON's After-sales Service.
- Only use original spare parts by SAMSON, which comply with the original specifications.

9.1 Periodic testing

Depending on the operating conditions, check the actuator at certain intervals to prevent possible failure before it can occur. Plant operators are responsible for drawing up an inspection and test plan.

Tip

Our after-sales service can support you in drawing up an inspection and test plan for your plant.

9.2 Preparation for servicing or conversion work

1. Lay out the necessary material and tools to have them ready for the intended work.
2. Put the actuator out of operation (see the 'Decommissioning' section).
3. Remove the actuator from the valve (see the 'Removal' section).

i Note

To remove an actuator with "stem extends" fail-safe action and/or with preloaded springs, a certain signal pressure must be applied to the actuator (see the 'Removal' section). Afterwards, the signal pressure must be removed and the air supply disconnected again and locked.

4. Relieve the compression from the preloaded springs. See 'Relieving the spring compression in the actuator' in the 'Removal' section.
5. Unthread and remove the nuts and bolts (including the washers) from around the actuator casing.

The following servicing and/or conversion work can be performed after preparation is completed:

- Replace the diaphragm (see section 9.4.1)
- Replace the actuator stem seals (see section 9.4.2)
- Reverse the direction of action (see section 9.5.1)

9.3 Mounting the actuator on the valve after servicing or conversion work

1. Mount the actuator (see the 'Installation' section).
2. Adjust the upper or lower bench range values (see the 'Start-up' section).

9.4 Service work

See Fig. 3-1 and Fig. 3-2 in the 'Design and principle of operation' section

9.4.1 Replacing the diaphragm

! NOTICE

Risk of malfunction due to damaged hose clamp.

- ➔ Do not reuse hose clamps.
- ➔ Use a new hose clamp every time the diaphragm is replaced.

! NOTICE

Risk of property damage and malfunction due to incorrect mounting of the hose clamp.

- ➔ Tighten the hose clamp by hand using a torque wrench. Observe the tightening torque and position it centrally.

a) Actuator stem extends

Refer to Fig. 9-1

1. Lift off the top diaphragm case (A1) and remove springs (A10).
2. Pull the diaphragm plate assembly consisting of the diaphragm plate (A5), diaphragm (A4) and actuator stem (A7) out of the bottom diaphragm case (A2).
3. Clamp the bottom section of the actuator stem (A7) into a vise using protective jaws. Make sure that the actuator stem is not damaged.

4. **240 cm²:** undo the latch of the hose clamp (A6). Take the hose clamp (A6) and diaphragm (A4) off the diaphragm plate (A5).

350 and 700 cm²: undo the latch of the hose clamp (A6). Take the compressor (A19), hose clamp (A6) and diaphragm (A4) off the diaphragm plate (A5).

5. Mount the new diaphragm (A4). Make sure the diaphragm is correctly aligned with the diaphragm plate. The imaginary

line through two opposing recesses for springs on the diaphragm plate must be aligned centrally between two bolting holes in the diaphragm (see Fig. 9-2).

6. Place the hose clamp (A6) evenly into the groove in the diaphragm (A4) intended for it.
7. **240 cm²:** turn the screw on the latch of the hose clamp until the hose clamp rests completely in the groove. Tighten the screw of the latch using a suitable tool. Observe tightening torques.

350 and 700 cm²: turn the screw on the latch of the hose clamp until only a gap of just a few millimeters remains between the diaphragm (A4) and hose clamp (A6).

Place and align the compressor (A19) beneath the clamp's latch (see Fig. 9-2). Tighten the screw of the latch using a suitable tool. Observe tightening torques.

8. Apply a suitable lubricant to the actuator stem (A7).

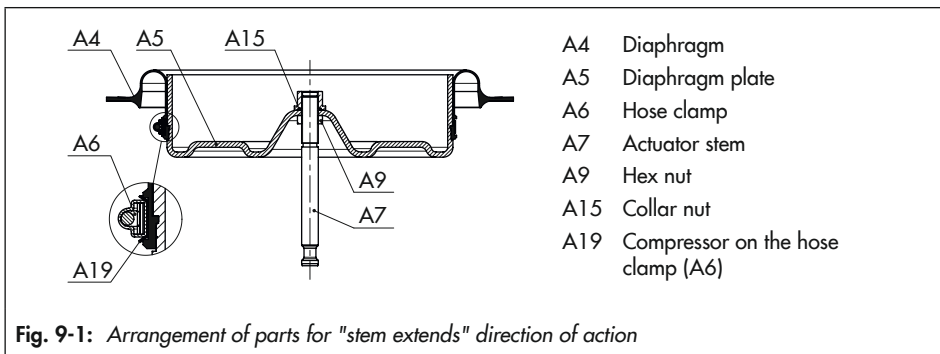

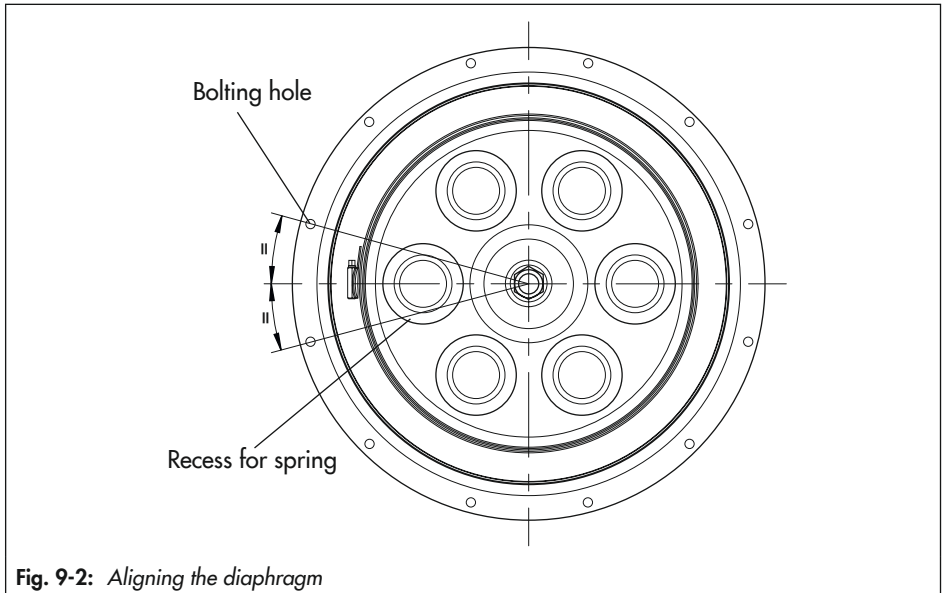

Fig. 9-2: *Aligning the diaphragm*

9. Place the diaphragm plate assembly consisting of the diaphragm plate (A5), new diaphragm (A4) and actuator stem (A7) into the bottom diaphragm case (A2). Make sure that the sealing elements are not damaged.
10. Place the springs (A10) into the bottom diaphragm case, centering them in the intended recesses.
11. Place on the top diaphragm case (A1).
12. If necessary, preload the springs (see the 'Start-up' section).
13. Fasten the top and bottom diaphragm cases (A1, A2) together using the nuts (A21) and bolts (A20). Observe tightening torques.

b) Actuator stem retracts

See Fig. 9-3

1. Lift off the top diaphragm case (A1).
2. Pull the diaphragm plate assembly consisting of the diaphragm plate (A5), diaphragm (A4) and actuator stem (A7) out of the actuator.
3. Take the springs (A10) out of the bottom diaphragm case (A2).
4. Clamp the bottom section of the actuator stem (A7) into a vise using protective jaws. Make sure that the actuator stem is not damaged.
5. **240 cm²:** undo the latch of the hose clamp (A6). Take the hose clamp (A6) and diaphragm (A4) off the diaphragm plate (A5).

Servicing and conversion

350 and 700 cm²: undo the latch of the hose clamp (A6). Take the compressor (A19), hose clamp (A6) and diaphragm (A4) off the diaphragm plate (A5).

6. Mount the new diaphragm (A4). Make sure the diaphragm is correctly aligned with the diaphragm plate. The imaginary line through two opposing recesses for springs on the diaphragm plate must be aligned centrally between two bolting holes in the diaphragm (see Fig. 9-2).
7. Place the hose clamp (A6) evenly into the groove in the diaphragm (A4) intended for it.
8. **240 cm²:** turn the screw on the latch of the hose clamp until the hose clamp rests completely in the groove. Tighten the screw of the latch using a suitable tool. Observe tightening torques.

350 and 700 cm²: turn the screw on the latch of the hose clamp until only a gap of just a few millimeters remains between the diaphragm (A4) and hose clamp (A6).

Place and align the compressor (A19) beneath the clamp's latch (see Fig. 9-2). Tighten the screw of the latch using a suitable tool. Observe tightening torques.

9. Apply a suitable lubricant to the actuator stem (A7).
10. Clamp the top diaphragm case (A1) with the opening facing upward into a suitable clamping fixture.
11. Place the diaphragm plate assembly consisting of the diaphragm plate (A5), new diaphragm (A4) and actuator stem (A7) with the actuator stem pointing upward into the diaphragm case (A1).
12. Place the springs (A10) in the diaphragm plate (A5), centering them in the intended recesses.
13. Carefully guide the bottom diaphragm case (A2) over the actuator stem (A7) and place it on the springs (A10). Make sure that the sealing elements are not damaged. Ensure that the compressed air connections on the cases (A1, A2) are correctly aligned with each other.

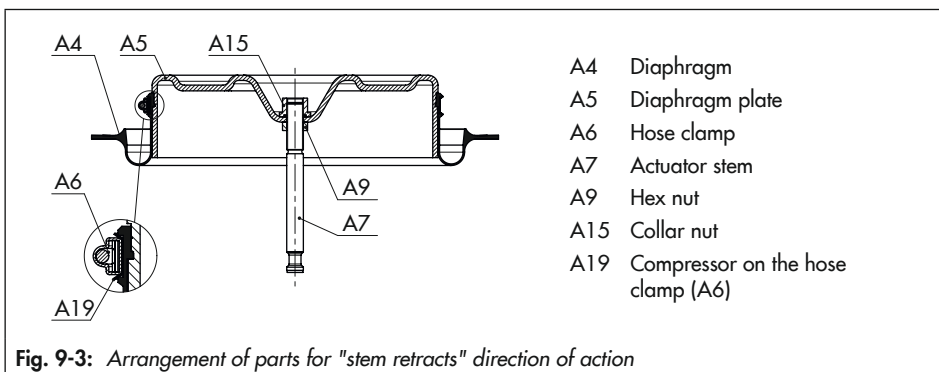

14. Fasten the top and bottom diaphragm cases (A1, A2) together using the nuts (A21) and bolts (A20). Observe tightening torques.

9.4.2 Replacing the actuator stem seals

Refer to Fig. 9-4

a) Actuator stem extends

1. Lift off the top diaphragm case (A1) and remove springs (A10).
2. Pull the diaphragm plate assembly consisting of the diaphragm plate (A5), diaphragm (A4) and actuator stem (A7) out of the bottom diaphragm case (A2).
3. Use a suitable punch to remove the radial shaft seal (A40).
4. Check the dry bearing (A42) and wiper (A41) and renew them, if necessary.
5. Apply a suitable lubricant to the seal lip of the new radial shaft seal.
6. Use a suitable tool to mount the radial shaft seal. Observe the correct alignment of the radial shaft seal (see Fig. 9-4).
7. Fill the cavity of the radial shaft seal, in which the spring is seated, with lubricant.
8. Apply a suitable lubricant to the actuator stem (A7).
9. Place the diaphragm plate assembly consisting of the diaphragm plate (A5), new diaphragm (A4) and actuator stem (A7) into the bottom diaphragm case (A2).

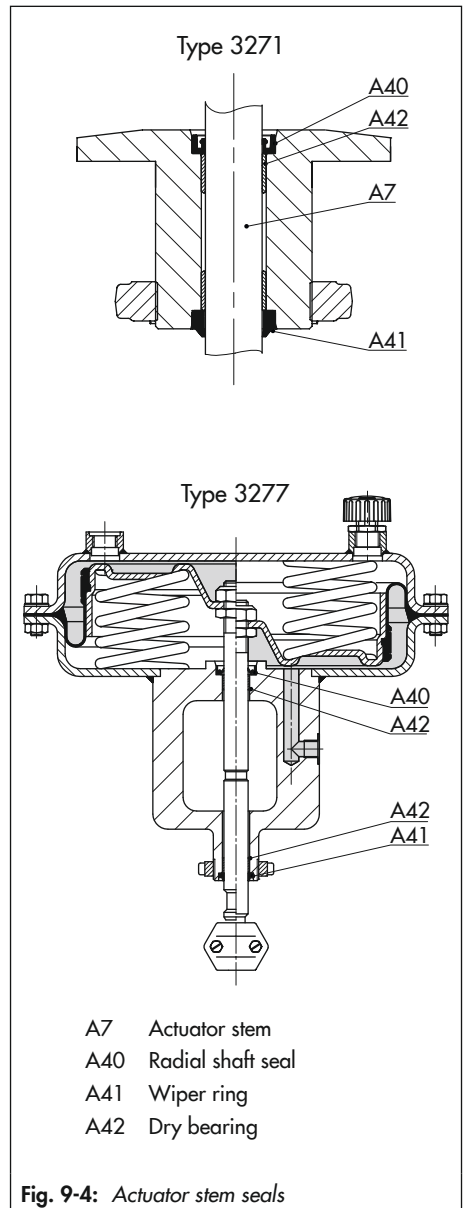

Fig. 9-4: Actuator stem seals

Servicing and conversion

Make sure that the sealing elements are not damaged. Ensure that the compressed air connections on the cases (A1, A2) are correctly aligned with each other.

10. Place the springs (A10) into the bottom diaphragm case, centering them in the intended recesses.
11. Place on the top diaphragm case (A1).
12. If necessary, preload the springs (see the 'Start-up' section).
13. Fasten the top and bottom diaphragm cases (A1, A2) together using the nuts (A21) and bolts (A20). Observe tightening torques.
8. Fill the cavity of the radial shaft seal, in which the spring is seated, with lubricant.
9. Apply a suitable lubricant to the actuator stem (A7).
10. Clamp the top diaphragm case (A1) with the opening facing upward into a suitable clamping fixture.
11. Place the diaphragm plate assembly together with the actuator stem (A7) pointing upward into the diaphragm case (A1).
12. Place the springs (A10) in the diaphragm plate (A5), centering them in the intended recesses.

b) Actuator stem retracts

1. Lift off the top diaphragm case (A1).
2. Pull the diaphragm plate assembly consisting of the diaphragm plate (A5), diaphragm (A4) and actuator stem (A7) out of the actuator.
3. Take the springs (A10) out of the bottom diaphragm case (A2).
4. Use a suitable punch to remove the radial shaft seal (A40).
5. Check the dry bearing (A42) and wiper (A41) and renew them, if necessary.
6. Apply a suitable lubricant to the seal lip of the new radial shaft seal.
7. Use a suitable tool to mount the radial shaft seal. Observe the correct alignment of the radial shaft seal (see Fig. 9-4).
13. Carefully guide the bottom diaphragm case (A2) over the actuator stem (A7) and place it on the springs (A10). Make sure that the sealing elements are not damaged. Ensure that the compressed air connections on the cases (A1, A2) are correctly aligned with each other.
14. Fasten the top and bottom diaphragm cases (A1, A2) together using the nuts (A21) and bolts (A20). Observe tightening torques.

9.5 Conversion work

See Fig. 3-1 and Fig. 3-2 in the 'Design and principle of operation' section

9.5.1 Reversing the direction of action (fail-safe action)

See Fig. 9-5

The direction of action (and fail-safe action) of pneumatic actuators can be changed. The fail-safe action is indicated on the nameplate by a symbol:

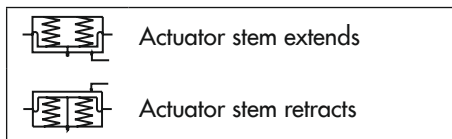

a) Reversal of the direction of action from stem extends to stem retracts

1. Lift off the top diaphragm case (A1) and remove springs (A10).
2. Pull the diaphragm plate assembly consisting of the diaphragm plate (A5), diaphragm (A4) and actuator stem (A7) out of the bottom diaphragm case (A2).
3. Clamp the bottom section of the actuator stem (A7) into a vise using protective jaws. Make sure that the actuator stem is not damaged.
4. Completely unscrew the collar nut (A15), while holding the nut (A9) stationary.

! NOTICE

Malfunction due to loosened nut (A9).

The nut (A9) on the actuator stem serves to adjust the dimension x .

→ Do not undo the nut (A9).

→ If the nut (A9) has been loosened, readjust the dimension x as specified in Table 9-1.

5. Remove the diaphragm plate (A5) with diaphragm (A4) from the actuator stem and place them back on in reverse order.
6. Tighten retaining nut (A82) while holding nut (A9) stationary. Observe tightening torques.
7. Unscrew the distance piece (A87).
8. Apply a suitable lubricant to the actuator stem (A7).
9. Clamp the top diaphragm case (A1) with the opening facing upward into a suitable clamping fixture.
10. Place the diaphragm plate assembly together with the actuator stem (A7) pointing upward into the diaphragm case (A1).
11. Place the springs (A10) in the diaphragm plate (A5), centering them in the intended recesses.
12. Carefully guide the bottom diaphragm case (A2) over the actuator stem (A7) and place it on the springs (A10). Make sure that the sealing elements are not damaged. Ensure that the compressed air connections on the cases (A1, A2) are correctly aligned with each other.

Servicing and conversion

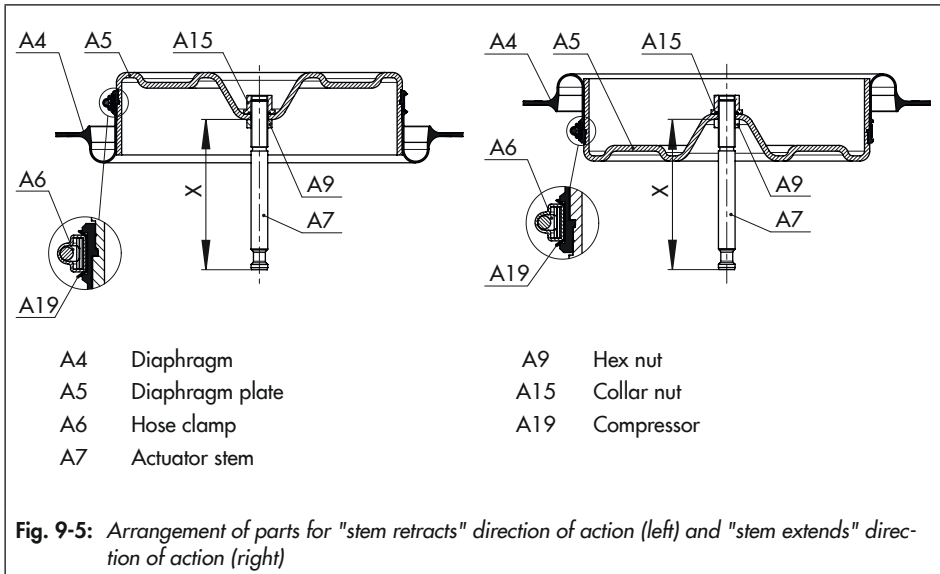

Table 9-1: Values for dimension *x* (see Fig. 9-5)

Type	Actuator area	Travel in mm	Dimension <i>x</i> in mm
			(top of the nut to the bottom of the actuator stem)
3271	240	15	98.25
	350	15	107.25
	700	30	144
3277	240	15	–
	350	15	209
	700	30	246

13. Fasten the top and bottom diaphragm cases (A1, A2) together using the nuts (A21) and bolts (A20). Observe tightening torques.
14. Unscrew the vent plug (A16) from the top signal pressure connection and screw it into the bottom connection (S).
The actuator springs, which now push against the diaphragm plate from below, cause the actuator stem to retract. The signal pressure is connected to the top connection (S) on the top diaphragm case. As a result, the actuator stem extends opposing the spring force as the signal pressure increases.
15. Affix a new nameplate with changed symbol and new configuration ID to the actuator.

b) Reversal of the direction of action from stem retracts to stem extends

1. Lift off the top diaphragm case (A1).
2. Pull the diaphragm plate assembly consisting of the diaphragm plate (A5), diaphragm (A4) and actuator stem (A7) out of the actuator.
3. Take the springs (A10) out of the bottom diaphragm case (A2).
4. Completely unscrew the collar nut (A15), while holding the nut (A9) stationary.

! NOTICE

Malfunction due to loosened nut (A9).

The nut (A9) on the actuator stem serves to adjust the dimension x .

→ Do not undo the nut (A9).

→ If the nut (A9) has been loosened, readjust the dimension x as specified in Table 9-1.

5. Clamp the bottom section of the actuator stem (A7) into a vise using protective jaws. Make sure that the actuator stem is not damaged.
6. Remove the diaphragm plate (A5) with diaphragm (A4) from the actuator stem and place them back on in reverse order.
7. Tighten the collar nut (A15), while holding the nut (A9) stationary. Observe tightening torques.
8. Apply a suitable lubricant to the actuator stem (A7).
9. Place the diaphragm plate assembly together with the actuator stem (A7) pointing downward into the bottom diaphragm case (A2). Make sure that the sealing elements are not damaged.
10. Place the springs (A10) into the bottom diaphragm case, centering them in the intended recesses.
11. Place on the top diaphragm case (A1).
12. If necessary, preload the springs (see the 'Start-up' section).

Servicing and conversion

13. Fasten the top and bottom diaphragm cases (A1, A2) together using the nuts (A21) and bolts (A20). Observe tightening torques.
14. Unscrew the vent plug (A16) from the bottom signal pressure connection and screw it into the top connection (S).
The actuator springs, which now push against the diaphragm plate from above, cause the actuator stem to extend. The signal pressure is connected to the bottom connection (S) on the bottom diaphragm case. As a result, the actuator stem retracts opposing the spring force as the signal pressure increases.
15. Affix a new nameplate with changed symbol and new configuration ID to the actuator.

9.6 Ordering spare parts and operating supplies

Contact your nearest SAMSON subsidiary or SAMSON's After-sales Service for information on spare parts, lubricants and tools.

Spare parts

See Annex for details on spare parts.

Lubricant

See document ► AB 0100 for details on suitable lubricants.

Tools

See document ► AB 0100 for details on suitable tools.

10 Decommissioning

The work described in this section is only to be performed by personnel appropriately qualified to carry out such tasks.

⚠ DANGER

Risk of bursting due to incorrect opening of pressurized equipment or components.

Pneumatic actuators are pressure equipment that may burst when handled incorrectly.

Flying projectile fragments or components can cause serious injury or even death.

Before working on the actuator:

- Depressurize all plant sections concerned and the actuator. Release any stored energy.

⚠ WARNING

Risk of personal injury due to preloaded springs.

Actuators with preloaded springs are under tension. These actuators can be identified by several longer bolts with nuts protruding from the bottom diaphragm case. Actuators with considerably preloaded springs are also labeled correspondingly (see the 'Markings on the device' section).

- Only open the actuator following the instructions in this document. See 'Relieving the spring compression in the actuator' in the 'Removal' section.

⚠ WARNING

Risk of personal injury due to exhaust air being vented.

The actuator is operated with air. As a result, air is vented during operation.

- Wear eye and hearing protection when working near the actuator.

⚠ WARNING

Crush hazard arising from the moving actuator stem.

- Do not insert hands or finger into the yoke while the air supply is connected to the actuator.
- Before working on the actuator, disconnect and lock the pneumatic air supply as well as the control signal.
- Do not impede the movement of the actuator stem by inserting objects into the yoke.
- Before unblocking the actuator stem after it has become blocked (e.g. due to seizing up after remaining in the same position for a long time), release any stored energy in the actuator (e.g. spring compression). See 'Relieving the spring compression in the actuator' in the 'Removal' section.

To decommission the actuator for service work or before removing it from the valve, proceed as follows:

1. Put the control valve out of operation. See associated valve documentation.
2. Disconnect the pneumatic air supply to depressurize the actuator.

11 Removal

The work described in this section is only to be performed by personnel appropriately qualified to carry out such tasks.

⚠ DANGER

Risk of bursting due to incorrect opening of pressurized equipment or components.

Pneumatic actuators are pressure equipment that may burst when handled incorrectly.

Flying projectile fragments or components can cause serious injury or even death.

Before working on the actuator:

- Depressurize all plant sections concerned and the actuator. Release any stored energy.

⚠ WARNING

Risk of personal injury due to preloaded springs.

Actuators with preloaded springs are under tension. These actuators can be identified by several longer bolts with nuts protruding from the bottom diaphragm case. Actuators with considerably preloaded springs are also labeled correspondingly (see the 'Markings on the device' section).

- Only open the actuator following the instructions in this document. See 'Relieving the spring compression in the actuator' in the 'Removal' section.

⚠ WARNING

Risk of personal injury due to exhaust air being vented.

The actuator is operated with air. As a result, air is vented during operation.

- Wear eye and hearing protection when working near the actuator.

⚠ WARNING

Crush hazard arising from the moving actuator stem.

- Do not touch the actuator stem or insert hands or finger into the yoke while the air supply is connected to the actuator.
- Before working on the actuator, disconnect and lock the pneumatic air supply as well as the control signal.
- Do not impede the movement of the actuator stem by inserting objects into the yoke.
- Before unblocking the actuator stem after it has become blocked (e.g. due to seizing up after remaining in the same position for a long time), release any stored energy in the actuator (e.g. spring compression). See 'Relieving the spring compression in the actuator' in the 'Removal' section.

Before removing the valve, make sure the following conditions are met:

- The actuator is put out of operation (see the 'Decommissioning' section).

Removal

11.1 Removing the actuator from the valve

1. Undo the clamps of the stem connector (A26/27).
2. Loosen the stem connector nut (9) and lock nut (10).
3. **Removing actuators with "stem extends" action with/without preloaded springs:** to undo the ring nut (A8), apply approx. 50 % signal pressure to open the valve.
4. Unscrew the ring nut (A8) on the valve bonnet (2).
5. Disconnect the signal pressure again.
6. Remove the ring nut (A8) and actuator from the valve.
7. Fasten the lock nut (10) and stem connector nut (9) on the valve.

11.2 Relieving the spring compression in the actuator

The long clamping bolts with long clamping nuts and the short bolts with short nuts are arranged evenly around the circumference of the actuator housing to fasten the top and bottom diaphragm cases together. The springs in the actuator are compressed using the long clamping nuts and bolts.

To relieve the compression of the springs in the actuator, proceed as follows:

1. Unthread and remove the short nuts and bolts (including the washers) on the diaphragm cases.

2. Loosen the long clamping nuts and bolts on the diaphragm cases evenly in a crisscross pattern to gradually relieve the spring compression. Hold the bolt head stationary with a suitable tool and apply the torque to the nuts.

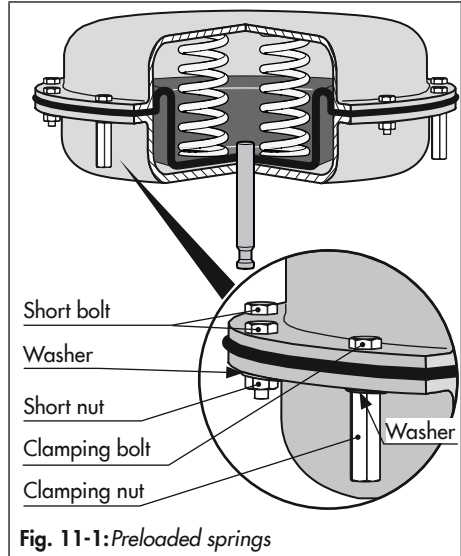

Fig. 11-1: Preloaded springs

12 Repairs

If the actuator does not function properly according to how it was originally sized or does not function at all, it is defective and must be repaired or exchanged.

! NOTICE

Risk of actuator damage due to incorrect service or repair work.

- ➔ Do not perform any repair work on your own.
- ➔ Contact SAMSON's After-sales Service for repair work.

12.1 Returning devices to SAMSON

Defective devices can be returned to SAMSON for repair.

Proceed as follows to return devices:

1. Exceptions apply concerning some special device models
 - ▶ www.samsongroup.com > Service & Support > After-sales Service.
2. Send an e-mail
 - ▶ retouren@samsongroup.com to register the return shipment including the following information:
 - Type
 - Article no.
 - Configuration ID
 - Original order

- Completed Declaration on Contamination, which can be downloaded from our website at
 - ▶ www.samsongroup.com > Service & Support > After-sales Service.

After checking your registration, we will send you a return merchandise authorization (RMA).

3. Attach the RMA (together with the Declaration on Decontamination) to the outside of your shipment so that the documents are clearly visible.
4. Send the shipment to the address given on the RMA.

i Note

Further information on returned devices and how they are handled can be found at

- ▶ www.samsongroup.com > Service & Support > After-sales Service.

13 Disposal

- Observe local, national and international refuse regulations.
- Do not dispose of components, lubricants and hazardous substances together with your household waste.

14 Certificates

The declaration of incorporation in compliance with Machinery Directive 2006/42/EC for Type 3271 and Type 3277 Pneumatic Actuators with 240, 350 and 700 cm² actuator areas is provided on the next page.

The certificates shown were up to date at the time of publishing. The latest certificates can be found on our website:

- ► www.samsongroup.com > *Products & Applications > Product selector > Actuators > 3271*
- ► www.samsongroup.com > *Products & Applications > Product selector > Actuators > 3277*

Other optional certificates are available on request.

DECLARATION OF INCORPORATION TRANSLATION



Declaration of Incorporation in Compliance with Machinery Directive 2006/42/EC

For the following products:

Type 3271 and Type 3277 Actuators

We certify that the Type 3271 and Type 3277 Actuators are partly completed machinery as defined in the Machinery Directive 2006/42/EC and that the safety requirements stipulated in Annex I, 1.1.2, 1.1.3, 1.1.5, 1.3.2, 1.3.4 and 1.3.7 are observed. The relevant technical documentation described in Annex VII, part B has been compiled.

Products we supply must not be put into service until the final machinery into which it is to be incorporated has been declared in conformity with the provisions of the Machinery Directive 2006/42/EC.

Operators are obliged to install the products observing the accepted industry codes and practices (good engineering practice) as well as the mounting and operating instructions. Operators must take appropriate precautions to prevent hazards that could be caused by the signal pressure and moving parts in/on the actuator.

The permissible limits of application and mounting instructions for the products are specified in the associated data sheets as well as the mounting and operating instructions; the documents are available in electronic form on the Internet at www.samson.de.

For product descriptions of the actuators, refer to:

- Types 3271 and 3277 Actuators: Mounting and Operating Instructions EB 8310-X

Referenced technical standards and/or specifications:

- VCI, VDMA, VGB: "Leitfaden Maschinenrichtlinie (2006/42/EG) – Bedeutung für Armaturen, Mai 2018" [German only]
- VCI, VDMA, VGB: "Zusatzdokument zum „Leitfaden Maschinenrichtlinie (2006/42/EG) – Bedeutung für Armaturen vom Mai 2018" [German only], based on DIN EN ISO 12100:2011-03

Comments:

- See mounting and operating instructions for residual hazards.
- Also observe the referenced documents listed in the mounting and operating instructions.

Persons authorized to compile the technical file:

SAMSON AG, Weismüllerstraße 3, 60314 Frankfurt am Main, Germany
Frankfurt am Main, 1 October 2019



Dr. Michael Heß
Director
Product Management and Technical Sales



Peter Scheermesser
Director
Product Upgrades and ETO Valves and Actuators

Revision no. 00

15 Annex

15.1 Tightening torques, lubricants and tools

► AB 0100 for tools, tightening torques and lubricants

15.2 Spare parts

1	Top diaphragm case
2	Bottom diaphragm case
4	Diaphragm
5	Diaphragm plate
6	Hose clamp
7	Actuator stem
8	Ring nut
9	Hex nut
10	Spring
11	Spring
12	Spring
15	Collar nut
16	Vent plug
19	Compressor on the hose clamp (6)
20	Hex bolt
21	Hex nut
22	Hex bolt (preloading)
23	Hex nut (preloading)
24	Screw plug
25	Washer
26/27	Stem connector clamp
28	Clamp with bracket
29	Hex screw
30	Hex nut
32	Hanger
40	Radial shaft seal
41	Wiper ring

42	Dry bearing
43	Hex screw for hanger (32)
49	Wiper ring ¹⁾
50	Top actuator stem
51	Stem connector
52	Screwed flange
54	Ring
55	Pointer
56	Hex nut ¹⁾
57	Coupling nut
58	Sliding washer
59	Yoke
60	Handwheel
61	Dowel pin
62	Dowel pin
63	Threaded pin
64	Cap screw
65	Hex screw
66	Lock nut
67	Snap ring
68	Axial needle seal
69	Washer
70	Adjustment nut
73	Cover
74	Lock nut
75	Top diaphragm case
76	Radial shaft seal
77	Dry bearing
100	Nameplate
101	Label (preloading)
106	Grooved pin
160*	Dust shield (option)

¹⁾ Only for version with 240 cm² actuator area

²⁾ Replaces collar nut (15) in version with travel stop or handwheel

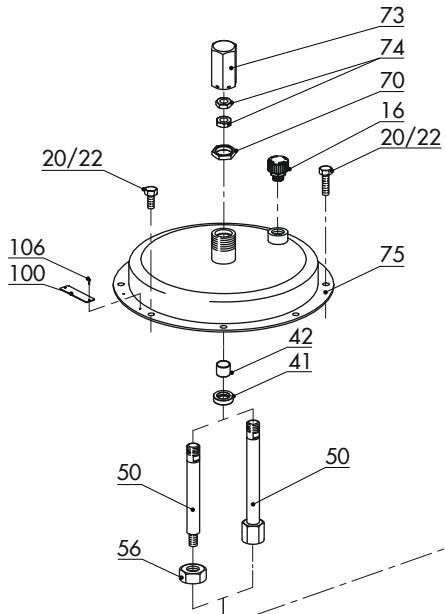
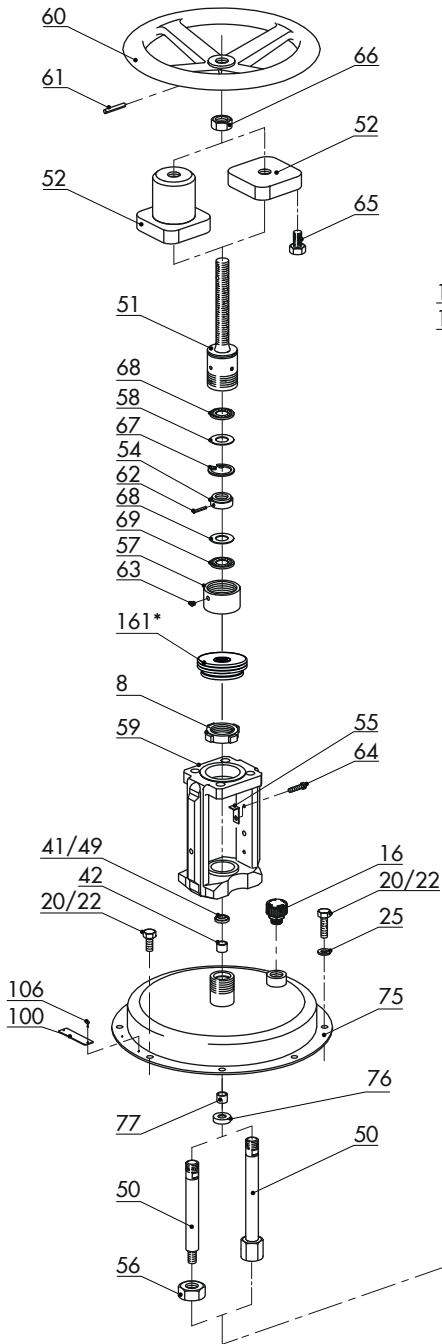

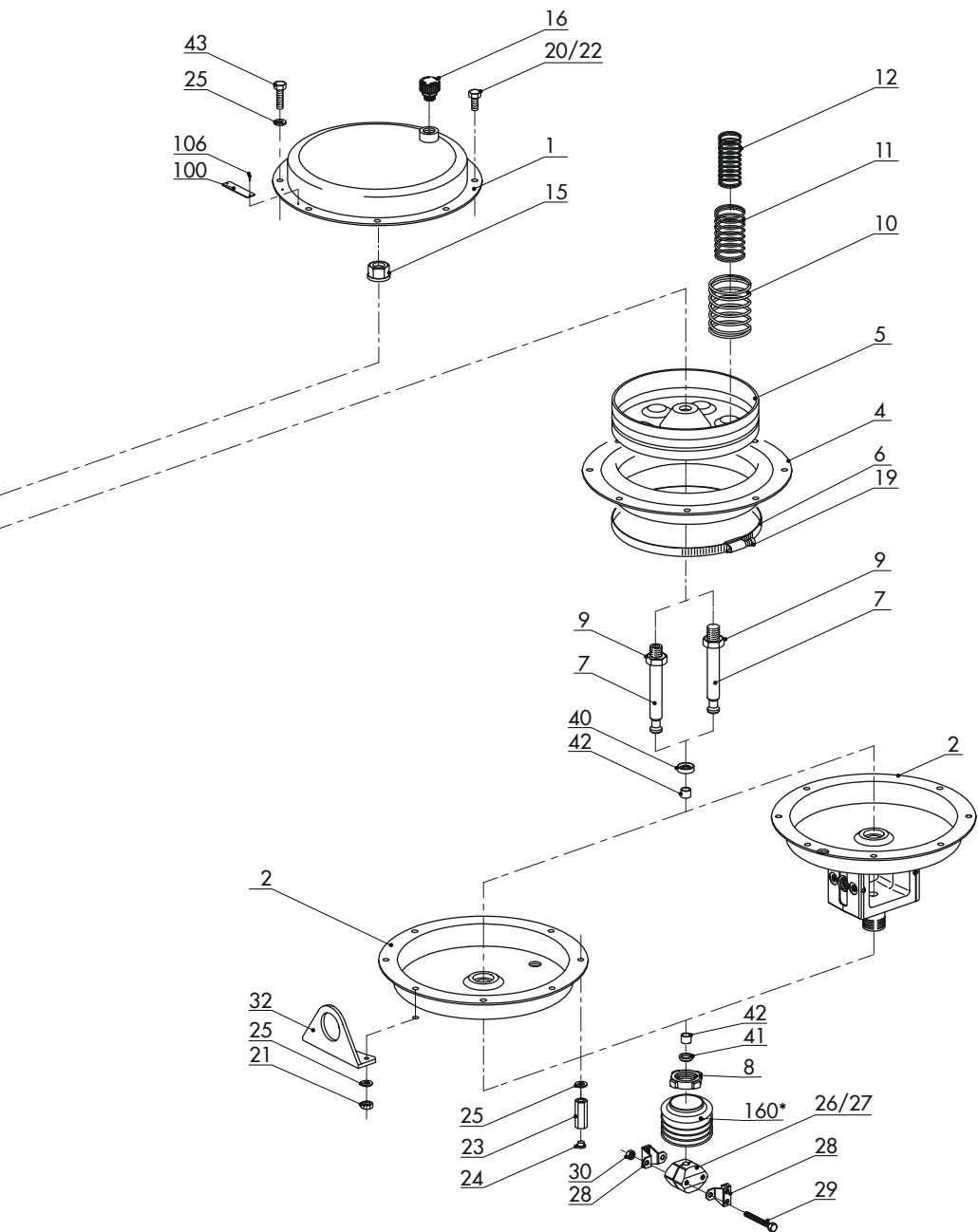

15.3 After-sales service

Contact our after-sales service for support concerning service or repair work or when malfunctions or defects arise.

E-mail address

You can reach our after-sales service at aftersalesservice@samsongroup.com.

Addresses of SAMSON AG and its subsidiaries

The addresses of SAMSON AG, its subsidiaries, representatives and service facilities worldwide can be found on our website (www.samsongroup.com) or in all SAMSON product catalogs.

Required specifications

Please submit the following details:

- Order number and position number in the order
- Type, model number, actuator area, travel, direction of action and bench range (e.g. 0.2 to 1 bar) or the operating range of the actuator
- Type designation of mounted valve (if applicable)
- Installation drawing

EB 8310-6 EN



SAMSON AKTIENGESELLSCHAFT
Weismüllerstraße 3 · 60314 Frankfurt am Main, Germany
Phone: +49 69 4009-0 · Fax: +49 69 4009-1507
samson@samsongroup.com · www.samsongroup.com